

301 & 303-BT GuardSwitch

Safety Switch

SAFETY
300-BT SERIES

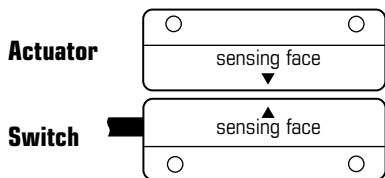
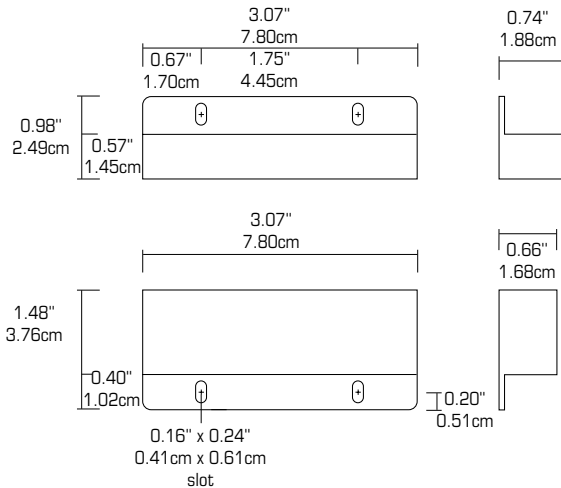

File E 115761 LR89176



U9880128199005
When used with INT Safety Monitor Relay

APPLICATIONS

- Requiring Highly Defeat Resistant Switches
- Meets European Safety Standard for the Highest Machine Risk Category when used with the INT Safety Relay
- Packaging Machinery
- Pharmaceutical Equipment
- Semiconductor Equipment
- Machine Tool Equipment
- Food Processing Machinery

General Specifications

Enclosure	Folded Stainless Steel
Temperature Range	-40°F to 180°F (-40°C to 80°C)
Environmental	Hermetically Sealed Contact Switch Encapsulated in Polyurethane
NEMA Rating	1, 2, 4, 4X, 5, 12, 12K
Protection Class	IP 66
Response Time (individual circuits)	1 msec The two circuits do not switch simultaneously and depend on the speed of the guard closure. A delay less than 50 msec is typical.
Life Cycles	100,000 Under Full Load; Up to 200,000,000 Under Dry Circuit
Lead Types/O.D.	18/4 SJTOW (K)/0.34" (0.86cm) 22/4 PVC Jacketed (J)/0.24" (0.62cm)
UL/CSA/TUV	All Models

ELECTRICAL SPECIFICATIONS (Applies to all models)

Circuit No.	Circuit Type	Contact Configuration	Load Rating	Switching Voltage	Switching Current
1	Switch	N.O.	40W/VA	48VAC/VDC	1.0ADC, 0.7AAC
2	Tamper	N.C.	10W/VA	48VAC/VDC	0.3A
2	w/optional LED	N.C.	0.1-1.4W	48VDC (3V drop)	30mA

ORDER INFORMATION					
Part Number ¹ 301 or 303	Contact ² Configuration	Sense Range ³ Minimum	Sense Range ³ Maximum	Break Range	Lead Length
301-BT-06 (J) (K)	DPST: 1 N.O., 1 N.C.	0.3" (0.8cm)	0.6" (1.5cm)	1.2" (3.0cm)	6' (1.8cm)
301-BT-12 (J) (K)	DPST: 1 N.O., 1 N.C.	0.3" (0.8cm)	0.6" (1.5cm)	1.2" (3.0cm)	12' (3.6cm)
301-BLT-06 (J) (K)	DPST: 1 N.O., 1 N.C. w/LED	0.3" (0.8cm)	0.6" (1.5cm)	1.2" (3.0cm)	6' (1.8cm)
301-BLT-12 (J) (K)	DPST: 1 N.O., 1 N.C. w/LED	0.3" (0.8cm)	0.6" (1.5cm)	1.2" (3.0cm)	12' (3.6cm)

Warning— Each electrical rating is an individual maximum and cannot be exceeded!

¹ The part numbers 301 and 303 are the same in all respects except the cable exits 301 left and 303 right.

² Configuration with actuator away from the switch

³ Proximity of ferrous materials usually reduces sense range — typically by 50%. The shape and type of material cause a wide diversity of effects. Testing is required to determine actual sense range for specific applications.

SENTROL INDUSTRIAL

12345 SW Leveton Drive, Tualatin, OR 97062

Tel: **800-247-9447** Fax: **503-691-7563**

http://www.sentrolindustrial.com

GuardSwitch™ Series 300 Safety Interlock Switch Installation Instructions



Description

The 301-BT Series 300 DPST safety interlock switch is designed for use with safety monitored relays or monitored circuits. To achieve the optimum Series 300 defeat resistant feature of the 301-BT, both the switch circuit (Circuit 1) and the tamper circuit (Circuit 2) must be connected. An optional third circuit can be provided to indicate at the panel which guard is open.

Notes:

1. Humidity Rating: 30 to 95%
2. Altitude Rating: Up to 1000m above sea level
3. Environmental: Pollution Degree II
4. Correct use of this control device is an essential part of proper machine cycle control.
5. Failure to follow ALL instructions could lead to serious bodily injury or death.
6. Maintenance to be done by qualified personnel only
7. The connecting cables between the INT devices and the switches must be located in an IP 23 type enclosure (minimum).
8. The mounting for the switch and the actuator magnet must be accomplished per this specification.
9. Non-removable hardware must be used for installation.
10. The housing of the 300-BT must be connected to the PE (Primary Earth) ground circuit via a lock washer on the mounting screw. The PE ground symbol must be placed adjacent to the screw.

Part Numbers

- 301-BT-06(J)(K)
- 301-BT-12(J)(K)
- 301-BLT-06(J)(K)
- 301-BLT-12(J)(K)
- 301-B3T-06(J)(K)
- 301-B3T-12(J)(K)
- 301-B3LT-06(J)(K)
- 301-B3LT-12(J)(K)
- 301-B_____
- 303-B_____

301-BT

303-BT

Installation

1. Position the switch and actuator so the labels are reading in the same direction (See Figure 1.)
2. Mount the switch on the stationary frame of the machine and mount the actuator on the moveable guard, door or gate. Keep the switch and actuator within the listed sense range. (See Ordering Information.) See Figure 2 for recommended mounting configurations.
3. Mounting on a ferrous material will effect the sense range a minimum of 50%. However, a 1/4" non-ferrous spacer positioned under the magnet and/or switch should restore most of the lost sense range.
4. For best protection against operator defeat, mount with non-removable screws, bolts or nuts. See ordering information for details.
5. **CAUTION:** When not used with a Sentrol INT relay particular care must be taken to determine the actual load of the switch circuit. High voltage transients from coils, motors, contactors and solenoids must be considered. Transient protection, such as back-to-back zener diodes (TransZorb®) or an RC network, is recommended for such loads to ensure that maximum ratings of the switch are not exceeded. Not recommended to be used with tungsten filament loads because of high current inrush surges. Line capacitance and load capacitance must be considered. Excessive line capacitance can be caused by cable lengths over 50' when using a maximum 48 VAC. A resistor can be added in series to limit the inrush current (at least 48 ohms for 24 Volt applications). The resistor can be added in series just before the load. The voltage drop and the power rating of the resistor must be considered. Voltage drop = $I \cdot R$; Watts = $I^2 \cdot R$ (I = maximum continuous current of the load).

continued

Fax (503-691-7563) or mail to register your warranty

Warranty Registration

Sentrol Industrial warranties this device for 5 years from date of installation or purchase. To register this product for the warranty, fill out this form and fax or mail it to Sentrol Industrial at the address listed above. ALL INFORMATION IS REQUIRED.

Company name _____

Company purchased from _____

Street address _____

Date of purchase or installation _____

City, State, Zip _____

Quantity installed _____

Completed by (name, title) _____

Type of machine installed on _____

6. When mounting the switch on an ungrounded machine, ground the switch housing by connecting your ground lead to one of the switch mounting screws.

Dimensions

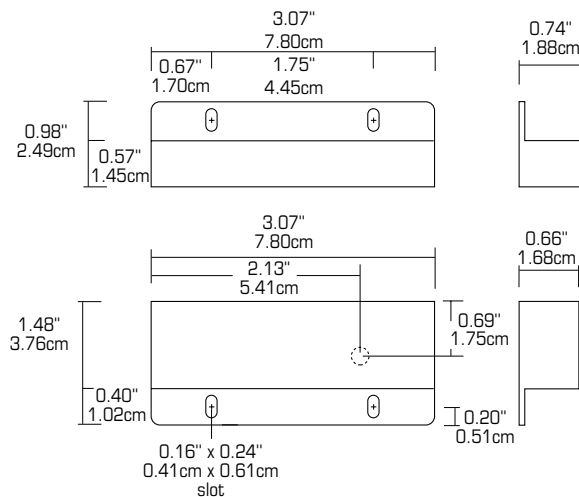
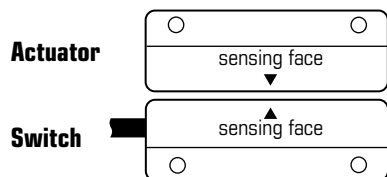
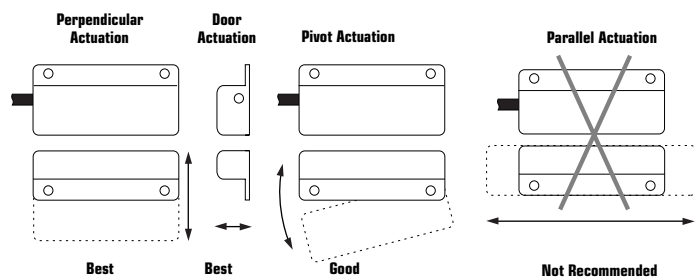

Figure 1



Mounting Configurations

Figure 2



The parallel actuation can result in on/off/on signal if the actuator passes by the switch rather than coming to rest in proximity to it. This is NOT a recommended configuration for safety interlock applications.

Wiring Diagram for Category 3

Inputs shown with safety gates/guards in closed position. One Series 300-BT GuardSwitch™ required for each safety gate.

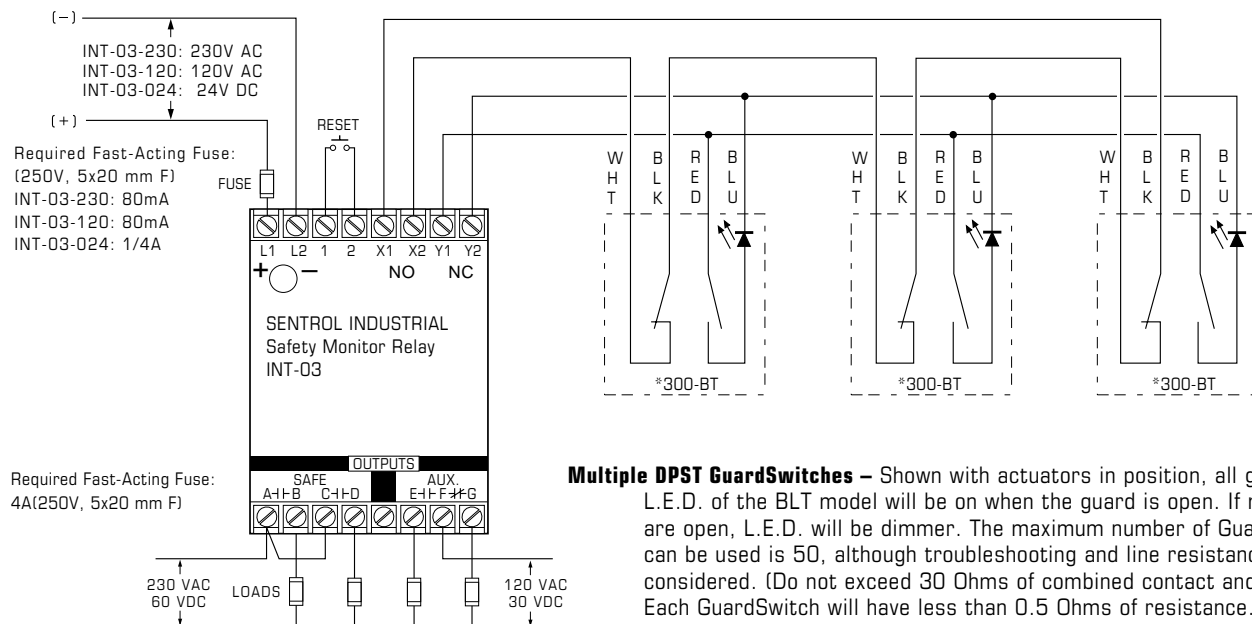

Multiple DPST GuardSwitches – Shown with actuators in position, all guards closed. The L.E.D. of the BLT model will be on when the guard is open. If multiple guards are open, L.E.D. will be dimmer. The maximum number of Guardswitches that can be used is 50, although troubleshooting and line resistance must be considered. (Do not exceed 30 Ohms of combined contact and line resistance. Each GuardSwitch will have less than 0.5 Ohms of resistance.)

Wiring Diagram for Category 4

Inputs shown with safety gate/guard in closed position. Two Series 300-BT GuardSwitches™ with one INT relay are required for each safety gate.

When first applying the INT Safety Monitor Relay, the inputs must be cycled to check for proper operation before the output contacts close. To cycle the inputs, the guard must be opened and then closed. This start-up test is sufficient; however, we recommend that the proper operation of the switches and relay be checked at least every 24 hours.

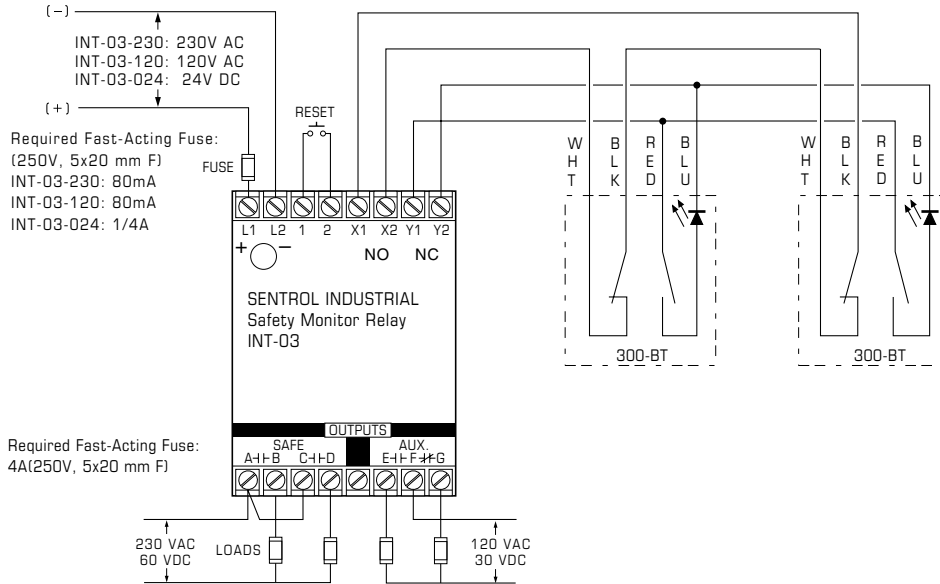

CE Compliance Information

These switches are TUV certified for CE applications only when used with the INT Safety Monitor Relays. See Risk Category 3 and Category 4 wiring diagrams above.

European Directives

Machinery Directive (89/392/EEC)

EMC Directive (89/336/EEC)

Low Voltage Directive (73/23/EEC)

Specific European Standards

EN60204-1 Safety of electrical equipment of industrial machines

EN292 Part 1, 2 Safety of Machinery, basic terminology, technical principles

EN954-1 Risk Assessment Category 3 or 4 depending on wiring method, see diagrams

EN55081-2 Electromagnetic Emissions

EN50082-2 Electromagnetic Immunity

EN1088 Interlocking Devices

EN947-5-3 Control Circuit Devices

EN50178 Safety of Electrical Equipment

IEC 664-1 Insulation requirements

IEC 68, part 2-1, 2-2, 2-3, 2-8, 2-14, 2-27, 2-30



General Specifications

Enclosure 304 Folded Stainless steel
 Temperature Range -40°F to 180°F (-40°C to 80°C)
 Environmental Hermetically Sealed Contact Switch
 Encapsulated in Polyurethane
 NEMA Rating 1, 2, 4, 4X, 5, 12, 12K
 Protection Class IP 66
 Response Time 1 msec (5.4VA); 10 msec (150VA)
 (individual circuits) The two circuits do not switch
 simultaneously, and depend on
 the speed of the guard closure.
 Based on closure speed of 1' per
 second and a gap of 1/8", a delay
 less than 50 msec is typical.

Life Cycles 100,000 Under Full Load;
 Up to 200,000,000 Under Dry Circuit

Lead Types/O.D. 18/4 SJTOW (K)/0.34" (0.86cm)
 22/4 PVC Jacketed (J)/0.19" (0.48cm)
 22/6 PVC Jacketed (J)/0.21" (0.53cm)

UL/CSA All Models

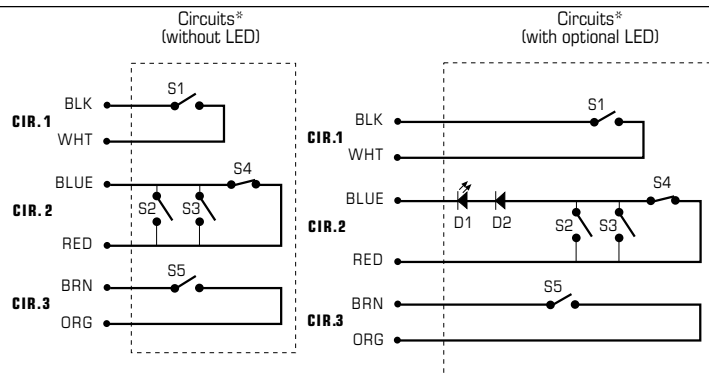

*Circuits shown with magnet actuator away from switch.
 S1, S5 Normally open reed switch¹, closed when actuator is within 0.6"
 S2, S3 Normally open reed switches, will close if misaligned or tampered with a
 standard magnet
 S4 Biased closed reed switch¹, open when actuator is between 0.3" and 0.6"

N.O. circuit: Black and white wires.
 N.C. biased tamper circuit: Red and blue wires.
 N.O. monitor circuit: Orange and brown wires.



FileE122942



LR89176

Electrical Specifications (Applies to all models)

Circuit No.	Circuit Type	Contact Configuration	Load Rating	Switching Voltage	Switching Current
1	Switch	N.O.	40W/VA	48VAC/VDC	1.0ADC, 0.7AAC
2	Tamper	N.C.	10W/VA	48VAC/VDC	0.3A
2	w/optional LED	N.C.	0.1–1.4W	48VDC(3V drop)	30mA
3	Monitor	N.O.	10W/VA	48VAC/VDC	0.3ADC, 0.3AAC

Ordering Information

Part Number ¹ 301 or 303	Contact ² Configuration	Sense Range ³ Minimum	Sense Range ³ Maximum	Break Range	Lead Length
301-BT-06(J)(K)	DPST: 1 N.O., 1 N.C.	0.3"(0.8cm)	0.6"(1.5cm)	1.2"(3.0cm)	6' (1.8cm)
301-BT-12(J)(K)	DPST: 1 N.O., 1 N.C.	0.3"(0.8cm)	0.6"(1.5cm)	1.2"(3.0cm)	12' (3.6cm)
301-BLT-06(J)(K)	DPST: 1 N.O., 1 N.C. w/LED	0.3"(0.8cm)	0.6"(1.5cm)	1.2"(3.0cm)	6' (1.8cm)
301-BLT-12(J)(K)	DPST: 1 N.O., 1 N.C. w/ LED	0.3"(0.8cm)	0.6"(1.5cm)	1.2"(3.0cm)	12' (3.6cm)
301-B3T-06(J)(K)	TPST: 2 N.O., 1 N.C.	0.3"(0.8cm)	0.6"(1.5cm)	1.2"(3.0cm)	6' (1.8cm)
301-B3T-12(J)(K)	TPST: 2 N.O., 1 N.C.	0.3"(0.8cm)	0.6"(1.5cm)	1.2"(3.0cm)	12' (3.6cm)
301-B3LT-06(J)(K)	TPST: 2 N.O., 1 N.C. w/ LED	0.3"(0.8cm)	0.6"(1.5cm)	1.2"(3.0cm)	6' (1.8cm)
301-B3LT-12(J)(K)	TPST: 2 N.O., 1 N.C. w/ LED	0.3"(0.8cm)	0.6"(1.5cm)	1.2"(3.0cm)	12' (3.6cm)

Accessories

Part Number	Tamper proof screws & screwdriver
1953	#6 x 3/4"L Tampruf Roundhead Screw
1954	#8 x 1-1/2"L Tampruf Roundhead Screw
1955	Tampruf Screwdriver
1956	Tampruf 1/4" Drive Bit for #6 and #8 screws

Warning— Each electrical rating is an individual maximum and cannot be exceeded!

- The part numbers 301 and 303 are the same in all respects except the cable exits 301 left and 303 right.
- Configuration with actuator away from the switch
- Proximity of ferrous materials usually reduces sense range — typically by 50%. The shape and type of material cause a wide diversity of effects. Testing is required to determine actual sense range for specific applications.

SENTROL INDUSTRIAL

12345 SW Leveton Dr., Tualatin, OR 97062
 Tel: **800-247-9447** Fax: **503-691-7563**
<http://www.sentrolindustrial.com>
 Technical Service: 800-648-7424
 FaxBack: 800-483-2495

Sentrol reserves the right
 to change specifications
 without notice.

©1999 Sentrol

SI-3706-0899
 1030523 Rev A

341 & 343-BT GuardSwitch

Safety Switch

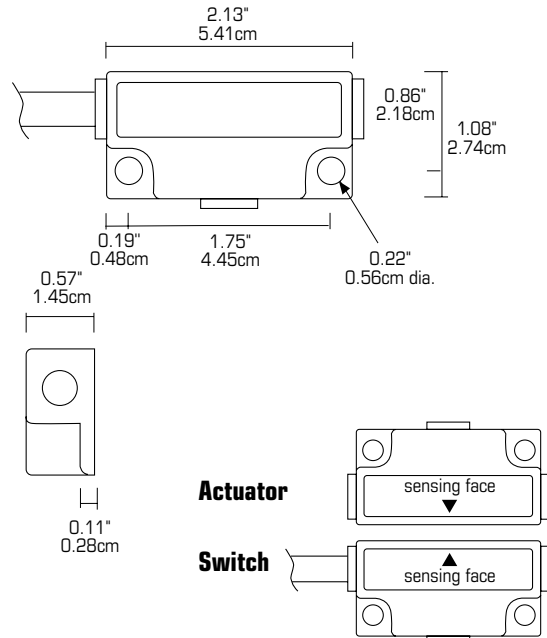
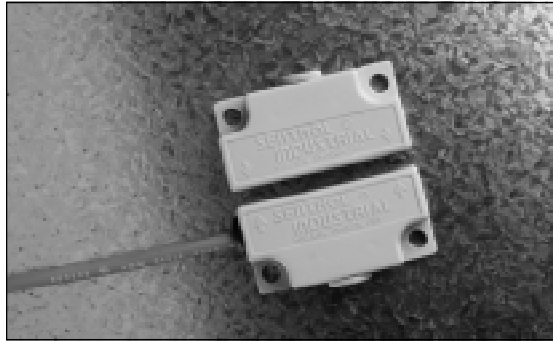

APPLICATIONS

- Requiring Highly Defeat Resistant Switches
- Meets European Safety Standard for the Highest Machine Risk Category when used with the INT Safety Relay
- Washdown Environments
- Packaging Machinery
- Pharmaceutical Equipment
- Semiconductor Equipment
- Food Processing Machinery

General Specifications

Enclosure	Kynar® Polyvinylidene Fluoride with sonic welded lid
Temperature Range	14°F to 180°F (-10°C to 80°C)
Environmental	Hermetically Sealed Contact Switch Encapsulated in Polyurethane
NEMA Rating	1, 2, 4, 4X, 5, 12, 12K, 13
Protection Class	IP 67
Response Time (individual circuits)	1 msec The two circuits do not switch simultaneously and depend on the speed of the guard closure. A delay less than 50 msec is typical.
Life Cycles	100,000 Under Full Load; Up to 200,000,000 Under Dry Circuit
Lead Types/O.D.	18/4 SJTOW (K)/0.34" (0.86cm) 22/4 PVC Jacketed (J)/0.24" (0.62cm)
UL/CSA/TUV	All Models

ELECTRICAL SPECIFICATIONS (Applies to all models)

Circuit No.	Circuit Type	Contact Configuration	Load Rating	Switching Voltage	Switching Current
1	Switch	N.O.	10W/VA	48VAC/VDC	0.3ADC, 0.3AAC
2	Tamper	N.C.	10W/VA	48VAC/VDC	0.3A
2	w/optional LED	N.C.	0.1-1.4W	48VDC(3V drop)	30mA
3	Monitor	N.O.	10W/VA	48VAC/VDC	0.3ADC, 0.3AAC



File E 122942 LR89176



U9880128199005
When used with INT Safety Monitor Relay

ORDER INFORMATION					
Part Number ¹ 341 or 343	Contact ² Configuration	Sense Range ³ Minimum	Sense Range ³ Maximum	Break Range	Lead Length
341-BT-06(J)(K)	DPST: 1 N.O., 1 N.C.	0.12"(0.3cm)	0.38"(1.0cm)	0.75"(1.9cm)	6' (1.8cm)
341-BT-12(J)(K)	DPST: 1 N.O., 1 N.C.	0.12"(0.3cm)	0.38"(1.0cm)	0.75"(1.9cm)	12' (3.6cm)
341-BLT-06(J)(K)	DPST: 1 N.O., 1 N.C. w/LED	0.12"(0.3cm)	0.38"(1.0cm)	0.75"(1.9cm)	6' (1.8cm)
341-BLT-12(J)(K)	DPST: 1 N.O., 1 N.C. w/LED	0.12"(0.3cm)	0.38"(1.0cm)	0.75"(1.9cm)	12' (3.6cm)
341-B3T-06(J)	TPST: 2 N.O., 1 N.C.	0.12"(0.3cm)	0.38"(1.0cm)	0.75"(1.9cm)	6' (1.8cm)
341-B3T-12(J)	TPST: 2 N.O., 1 N.C.	0.12"(0.3cm)	0.38"(1.0cm)	0.75"(1.9cm)	12' (3.6cm)
341-B3LT-06(J)	TPST: 2 N.O., 1 N.C. w/LED	0.12"(0.3cm)	0.38"(1.0cm)	0.75"(1.9cm)	6' (1.8cm)
341-B3LT-12(J)	TPST: 2 N.O., 1 N.C. w/LED	0.12"(0.3cm)	0.38"(1.0cm)	0.75"(1.9cm)	12' (3.6cm)

Warning— Each electrical rating is an individual maximum and cannot be exceeded!

¹ The part numbers 341 and the 343 are the same in all respects except the cable exits 341 left and 343 right.
² Configuration with actuator away from the switch
³ Proximity of ferrous materials usually reduces sense range — typically by 50%. The shape and type of material cause a wide diversity of effects. Testing is required to determine actual sense range for specific applications.

SENTROL INDUSTRIAL

12345 SW Leveton Drive, Tualatin, OR 97062

Tel: **800-247-9447** Fax: **503-691-7563**

http://www.sentrolindustrial.com



Description

The 341-BT Series 300 DPST safety interlock switch is designed for use with safety monitored relays or monitored circuits. To achieve the optimum Series 300 defeat resistant feature of the 341-BT, both the switch circuit (Circuit 1) and the tamper circuit (Circuit 2) must be connected. An optional third circuit can be provided to indicate at the panel which guard is open

Notes:

1. Humidity Rating: 30 to 95%
2. Altitude Rating: Up to 1000m above sea level
3. Environmental: Pollution Degree II
4. Correct use of this control device is an essential part of proper machine cycle control.
5. Failure to follow ALL instructions could lead to serious bodily injury or death.
6. Maintenance to be done by qualified personnel only
7. The connecting cables between the INT devices and the switches must be located in an IP 23 type enclosure (minimum).
8. The mounting for the switch and the actuator magnet must be accomplished per this specification.
9. Non-removable hardware must be used for installation.
10. The housing of the 300-BT Series GuardSwitches must be connected to the PE (Primary Earth) ground circuit via a lock washer on the mounting screw. The PE ground symbol must be placed adjacent to the screw.

Part Numbers

- 341-BT-06(J)(K)
- 341-BT-12(J)(K)
- 341-B3T-06J
- 341-B3T-12J
- 341-BLT-06(J)(K)
- 341-BLT-12(J)(K)
- 341-B3LT-06J
- 341-B3LT-12J
- 341-B_____
- 343-B_____

341-BT

343-BT

GuardSwitch™ Series 300 Safety Interlock Switch

Installation Instructions

Installation

1. Position the switch and actuator so the labels are reading in the same direction (See Figure 1.)
2. Mount the switch on the stationary frame of the machine and mount the actuator on the moveable guard, door or gate. Keep the switch and actuator within the listed sense range. (See Ordering Information.)
See Figure 2 for recommended mounting configurations.
3. Mounting on a ferrous material will effect the sense range a minimum of 50%. However, a 1/4" non-ferrous spacer positioned under the actuator and/or switch should restore most of the lost sense range.
4. For best protection against operator defeat, mount with non-removable screws, bolts or nuts (see Accessories).
5. **CAUTION:** When not used with a Sentrol INT safety relay, particular care must be taken to determine the actual load of the switch circuit. High voltage transients from coils, motors, contactors, and solenoids must be considered. Transient protection, such as back-to-back zener diodes (TransZorb®) or an RC network, is recommended for such loads to ensure that maximum ratings of the switch are not exceeded. Not recommended to be used with tungsten filament loads because of high current inrush surges. Line capacitance and load capacitance must be considered. Excessive line capacitance can be caused by cable lengths over 50' when using a maximum 48 VAC. A resistor can be added in series to limit

continued

Fax (503-691-7563) or mail to register your warranty

Warranty Registration

Sentrol Industrial warranties this device for 5 years from date of installation or purchase. To register this product for the warranty, fill out this form and fax or mail it to Sentrol Industrial at the address listed above. ALL INFORMATION IS REQUIRED.

Company name _____

Company purchased from _____

Street address _____

Date of purchase or installation _____

City, State, Zip _____

Quantity installed _____

Completed by (name, title) _____

Type of machine installed on _____

the inrush current (at least 48 Ohms for 24V applications). The resistor can be added in series just before the load. The voltage drop and the power rating of the resistor must be considered. Voltage drop = $I \cdot R$; Watts = $I^2 R$ (I = maximum continuous current of the load).

- When mounting the switch on an ungrounded machine, ground the switch housing by connecting your ground lead to one of the switch mounting screws.

Dimensions

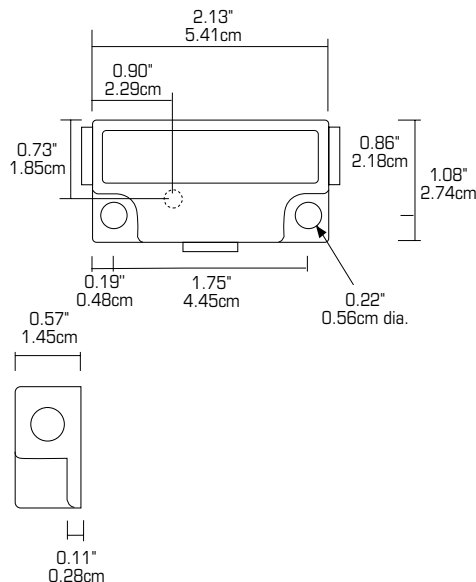
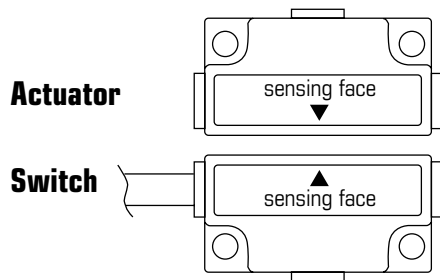
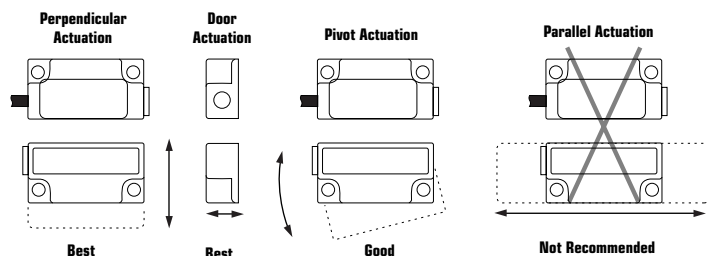

Figure 1



Mounting Configurations

Figure 2



The parallel actuation can result in on/off/on signal if the actuator passes by the switch rather than coming to rest in proximity to it. This is NOT a recommended configuration for safety interlock applications.

Wiring Diagram for Category 3

Inputs shown with safety gates/guards in closed position. One Series 300-BT GuardSwitch™ required for each safety gate.

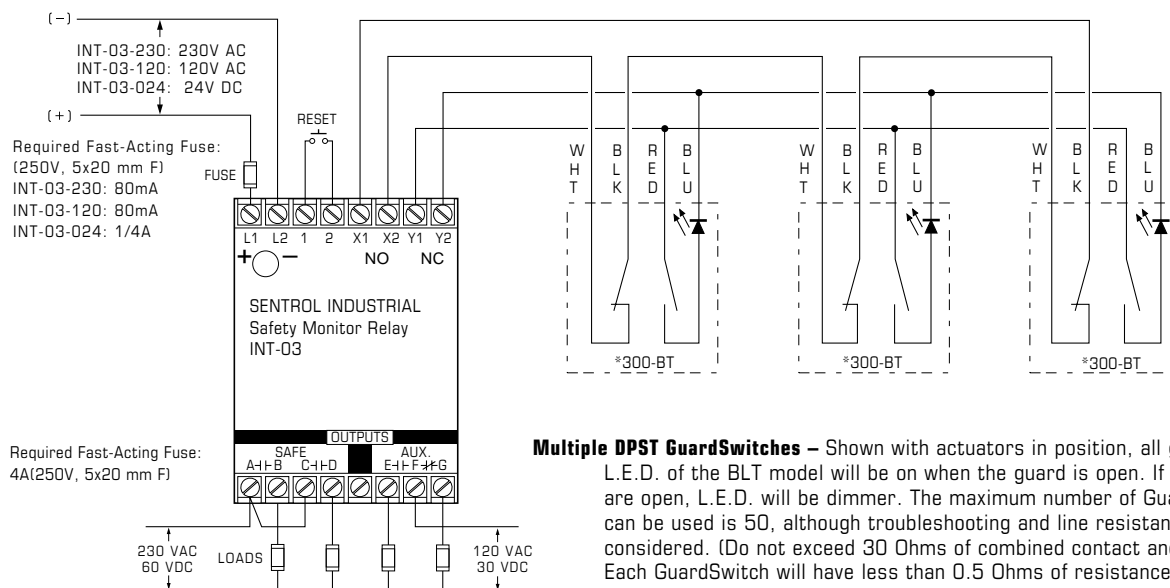

Multiple DPST GuardSwitches – Shown with actuators in position, all guards closed. The L.E.D. of the BLT model will be on when the guard is open. If multiple guards are open, L.E.D. will be dimmer. The maximum number of Guardswitches that can be used is 50, although troubleshooting and line resistance must be considered. (Do not exceed 30 Ohms of combined contact and line resistance. Each GuardSwitch will have less than 0.5 Ohms of resistance.)

Wiring Diagram for Category 4

Inputs shown with safety gate/guard in closed position. Two Series 300-B GuardSwitches™ with one INT relay are required for each safety gate.

When first applying the INT Safety Monitor Relay, the inputs must be cycled to check for proper operation before the output contacts close. To cycle the inputs, the guard must be opened and then closed. This start-up test is sufficient; however, we recommend that the proper operation of the switches and relay be checked at least every 24 hours.

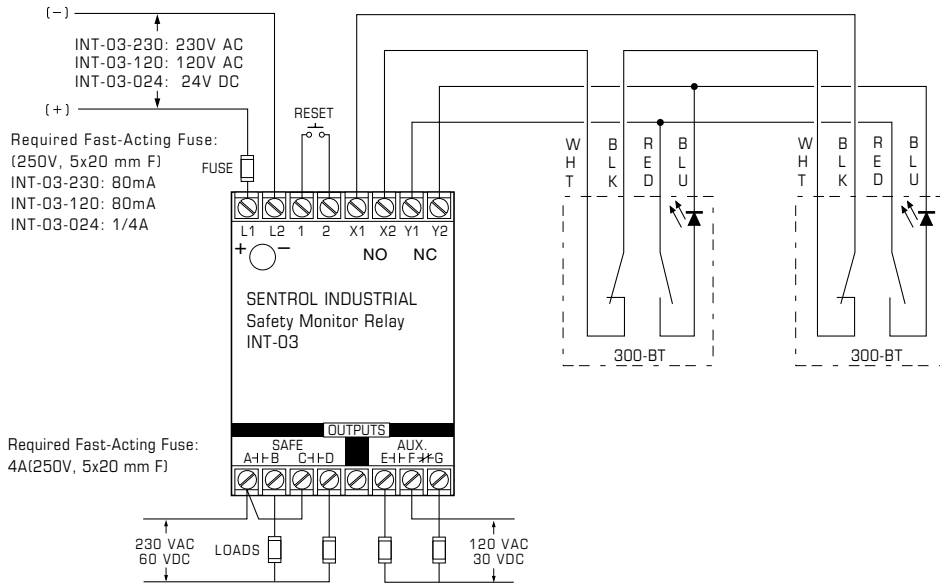

CE Compliance Information

These switches are TUV certified for CE applications only when used with the INT Safety Monitor Relays. See Risk Category 3 and Category 4 wiring diagrams above.

European Directives

Machinery Directive (89/392/EEC)

EMC Directive (89/336/EEC)

Low Voltage Directive (73/23/EEC)

Specific European Standards

EN60204-1 Safety of electrical equipment of industrial machines

EN292 Part 1, 2 Safety of Machinery, basic terminology, technical principles

EN954-1 Risk Assessment Category 3 or 4 depending on wiring method, see diagrams

EN55081-2 Electromagnetic Emissions

EN50082-2 Electromagnetic Immunity

EN1088 Interlocking Devices

EN947-5-3 Control Circuit Devices

EN50178 Safety of Electrical Equipment

IEC 664-1 Insulation requirements

IEC 68, part 2-1, 2-2, 2-3, 2-8, 2-14, 2-27, 2-30



General Specifications

Enclosure Kynar[®], Polyvinylidene Fluoride
 Temperature Range 14°F to 150°F (-10°C to 65°C)
 Environmental Hermetically Sealed Contact Switch
 Encapsulated in Polyurethane
 NEMA Rating 1, 2, 4, 4X, 5, 12, 12K, 13
 Protection Class IP 67
 Response Time 1 msec
 (individual circuits)

The two circuits do not switch simultaneously, and depend on the speed of the guard closure. Based on closure speed of 1" per second and a gap of 1/8", a delay less than 50 msec is typical.

Life Cycles 100,000 Under Full Load;
 Up to 200,000,000 Under Dry Circuit
 Lead Types/O.D. 18/4 SJTOW (K)/0.34" (0.86cm)
 22/4 PVC Jacketed (J)/0.19" (0.48cm)
 22/6 PVC Jacketed (J)/0.21" (0.53cm)
 UL/CSA/TUV All Models

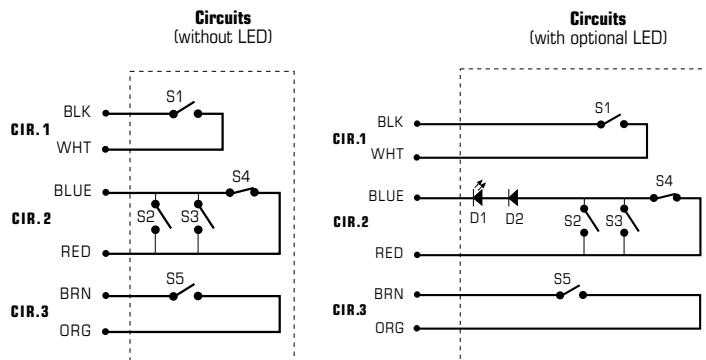

*Circuits shown with magnet actuator away from switch.

- S1, S5 Normally open reed switch, closed when actuator is within 0.4"
- S2, S3 Normally open reed switches, will close if misaligned or tampered with a standard magnet
- S4 Biased closed reed switch, open when actuator is between 0.15" and 0.4"
- S5 Normally open reed switch, closed when actuator is within 0.4"

N.O. circuit: Black and white wires.
 N.C. biased tamper circuit: Red and blue wires.
 N.O. monitor circuit: Orange and brown wires.



Electrical Specifications

Circuit No.	Circuit Type	Contact Configuration	Load Rating	Switching Voltage AC/DC	Switching Current AC/DC
1	Switch	N.O.	10W/VVA	48VAC/VDC	0.2A
2	Tamper	N.C.	10W/VVA	48VAC/VDC	0.2A
2	w/optional LED	N.C.	0.1–1.4W	48VDC(3V drop)	30mA
3	Monitor	N.O.	10W/VVA	48VAC/VDC	0.2A

Ordering Information

Part Number ¹ 341 or 343	Contact ² Configuration	Sense Range ³ Minimum	Sense Range ³ Maximum	Break Range	Lead Length
341-BT-06(J)(K)	DPST: 1 N.O., 1 N.C.	0.12"(0.3cm)	0.38"(1.0cm)	0.75"(1.9cm)	6' (1.8m)
341-BT-12(J)(K)	DPST: 1 N.O., 1 N.C.	0.12"(0.3cm)	0.38"(1.0cm)	0.75"(1.9cm)	12' (3.6m)
341-BLT-06(J)(K)	DPST: 1 N.O., 1 N.C. w/LED	0.12"(0.3cm)	0.38"(1.0cm)	0.75"(1.9cm)	6' (1.8m)
341-BLT-12(J)(K)	DPST: 1 N.O., 1 N.C. w/ LED	0.12"(0.3cm)	0.38"(1.0cm)	0.75"(1.9cm)	12' (3.6m)
341-B3T-06(J)	TPST: 2 N.O., 1 N.C.	0.12"(0.3cm)	0.38"(1.0cm)	0.75"(1.9cm)	6' (1.8m)
341-B3T-12(J)	TPST: 2 N.O., 1 N.C.	0.12"(0.3cm)	0.38"(1.0cm)	0.75"(1.9cm)	12' (3.6m)
341-B3LT-06(J)	TPST: 2 N.O., 1 N.C. w/LED	0.12"(0.3cm)	0.38"(1.0cm)	0.75"(1.9cm)	6' (1.8m)
341-B3LT-12(J)	TPST: 2 N.O., 1 N.C. w/LED	0.12"(0.3cm)	0.38"(1.0cm)	0.75"(1.9cm)	12' (3.6m)

Accessories

Part Number	Tamper proof screws & screwdriver
1953	#6 x 3/4"L Tampruf Roundhead Screw
1954	#8 x 1-1/2"L Tampruf Roundhead Screw
1955	Tampruf [®] Screwdriver
1956	Tampruf [®] 1/4" Drive Bit for #6 and #8 Screws

Warning— Each electrical rating is an individual maximum and cannot be exceeded!

¹ The part numbers 341 and 343 are the same in all respects except the conduit connection exits 341 left and 343 right.

² Configuration with actuator away from the switch

³ Proximity of ferrous materials usually reduces sense range — typically by 50%. The shape and type of material cause a wide diversity of effects. Testing is required to determine actual sense range for specific applications.

SENTROL INDUSTRIAL

12345 SW Leveton Dr., Tualatin, OR 97062
 Tel: **800-247-9447** Fax: **503-691-7563**
<http://www.sentrolindustrial.com>
 Technical Service: 800-648-7424
 FaxBack: 800-483-2495

Sentrol reserves the right to change specifications without notice.

©1999 Sentrol

SI-3706-0899
 1030523 Rev A

371-BT GuardSwitch

SAFETY
300-BT SERIES

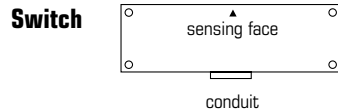
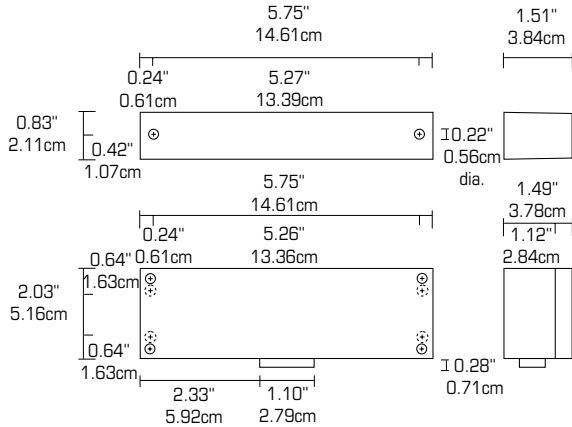

File E 122942 LR89176



U9880128199005
When used with INT Safety
Monitor Relay

ORDER INFORMATION					
Part Number	Contact ¹ Configuration	Sense Range ² Minimum	Sense Range ² Maximum	Break Range	Terminal Type
371-BT	DPST: 1 N.O., 1 N.C.	0.3" (0.8cm)	0.6" (1.5cm)	1.2" (3.0cm)	#6 screws

Warning— Each electrical rating is an individual maximum and cannot be exceeded!

- ¹ Configuration with actuator away from the switch
- ² Proximity of ferrous materials usually reduces sense range — typically by 50%. The shape and type of material cause a wide diversity of effects. Testing is required to determine actual sense range for specific applications.

Safety Switch

APPLICATIONS

- Requiring Explosion-Proof Enclosure for Hazardous Locations
- Meets European Safety Standard for the Highest Machine Risk Category when used with the INT Safety Relay
- UL Enclosure Classified for Use in Hazardous Locations: Class I, Group B, C, D Class II, Group E, F, G Class III, Divisions 1 & 2

General Specifications

Enclosure	UL Explosion Proof, Die Cast Aluminum
Temperature Range	-40°F to 180°F (-40°C to 80°C)
Environmental	Hermetically Sealed Contact Switch Encapsulated in Polyurethane
NEMA Rating	1, 2, 5
Protection Class	IP 64
Response Time (individual circuits)	1 msec The two circuits do not switch simultaneously and depend on the speed of the guard closure. A delay less than 50 msec is typical.
Life Cycles	100,000 Under Full Load; Up to 200,000,000 Under Dry Circuit
Conduit Connection	1/2" Threaded NPT
UL/CSA/TUV	All Models

ELECTRICAL SPECIFICATIONS

Circuit No.	Circuit Type	Contact Configuration	Load Rating	Switching Voltage	Switching Current
1	Switch	N.O.	40W/VA	48VAC/VDC	1.0ADC, 0.7AAC
2	Tamper	N.C.	10W/VA	48VAC/VDC	0.3A

SENTROL INDUSTRIAL

12345 SW Leveton Drive, Tualatin, OR 97062

Tel: **800-247-9447** Fax: **503-691-7563**

http://www.sentrolindustrial.com

Part Numbers

- 371-BT
- 371-B_____



GuardSwitch™ Series 300 Safety Interlock Switch Installation Instructions

Description

The 371-BT Series DPST safety interlock switch is designed for use with safety monitored relays or monitored circuits. To achieve the optimum Series 300 defeat resistant feature of the 371-BT, both the switch circuit (Circuit 1) and the tamper circuit (Circuit 2) must be connected.

Notes:

1. Humidity Rating: 30 to 95%
2. Altitude Rating: Up to 1000m above sea level
3. Environmental: Pollution Degree II
4. Correct use of this control device is an essential part of proper machine cycle control.
5. Failure to follow ALL instructions could lead to serious bodily injury or death.
6. Maintenance to be done by qualified personnel only
7. The connecting cables between the INT devices and the switches must be located in an IP 23 type enclosure (minimum).
8. The mounting for the switch and the actuator magnet must be accomplished per this specification.
9. Non-removable hardware must be used for installation.
10. The housing of the 300-BT must be connected to the PE (Primary Earth) ground circuit via a lock washer on the mounting screw. The PE ground symbol must be placed adjacent to the screw.



Installation

1. Position the switch and actuator so the labels are reading in the same direction.
(See Figure 1.)
2. Mount the switch on the stationary frame of the machine and mount the actuator on the moveable guard, door or gate. Keep the switch and actuator within the listed sense range. (See Ordering Information.)
See Figure 2 or recommended mounting configurations.
3. Mounting on a ferrous material will effect the sense range a minimum of 50%. However, a 1/4" non-ferrous spacer positioned under the actuator and/or switch should restore most of the lost sense range.
4. For best protection against operator defeat, mount with non-removable screws, bolts or nuts (see Accessories).
5. **CAUTION:** When not used with a Sentrol INT safety relay, particular care must be taken to determine the actual load of the switch circuit. High voltage transients from coils, motors, contactors, and solenoids must be considered. Transient protection, such as back-to-back zener diodes (TransZorb®) or an RC network, is recommended for such loads to ensure that maximum ratings of the switch are not exceeded. Not recommended to be used with tungsten filament loads because of high current inrush surges. Line capacitance and load capacitance

continued

Fax (503-691-7563) or mail to register your warranty

Warranty Registration

Sentrol Industrial warranties this device for 5 years from date of installation or purchase. To register this product for the warranty, fill out this form and fax or mail it to Sentrol Industrial at the address listed above. ALL INFORMATION IS REQUIRED.

Company name _____

Company purchased from _____

Street address _____

Date of purchase or installation _____

City, State, Zip _____

Quantity installed _____

Completed by (name, title) _____

Type of machine installed on _____

must be considered. Excessive line capacitance can be caused by cable lengths over 50' when using a maximum 48 VAC. A resistor can be added in series to limit the inrush current (at least 48 Ohms for 24V applications). The resistor can be added in series just before the load. The voltage drop and the power rating of the resistor must be considered. Voltage drop = $I \cdot R$; Watts = $I^2 R$ (I = maximum continuous current of the load).

- When mounting the switch on an ungrounded machine, ground the switch housing by connecting your ground lead to one of the switch mounting screws.

Figure 1

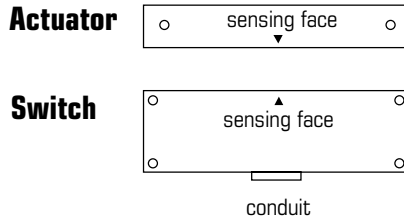

Dimensions

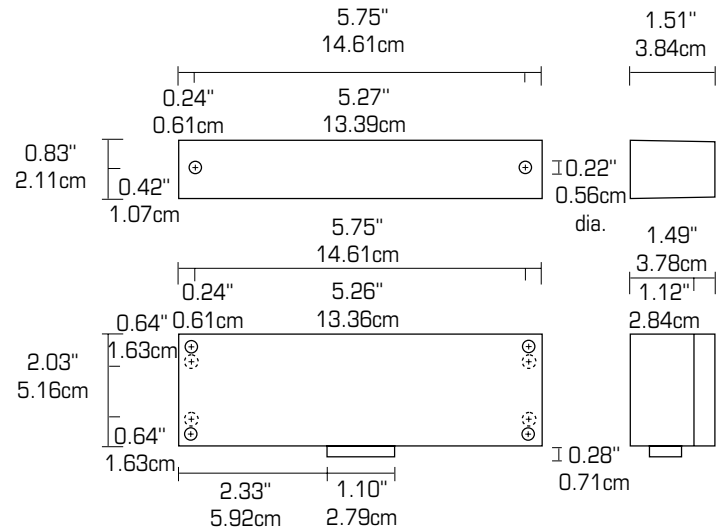

Mounting Configurations

Figure 2

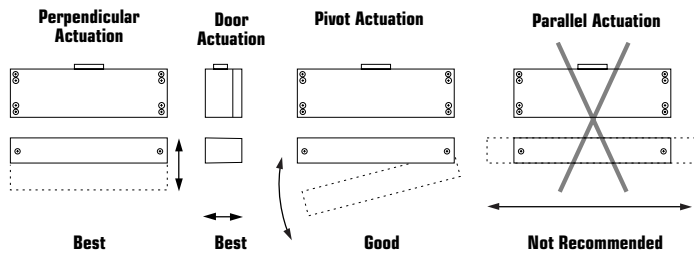

The parallel actuation can result in on/off/on signal if the actuator passes by the switch rather than coming to rest in proximity to it. This is NOT a recommended configuration for safety interlock applications.

Wiring Diagram for Category 3

Inputs shown with safety gates/guards in closed position. One Series 300-BT GuardSwitch™ required for each safety gate.

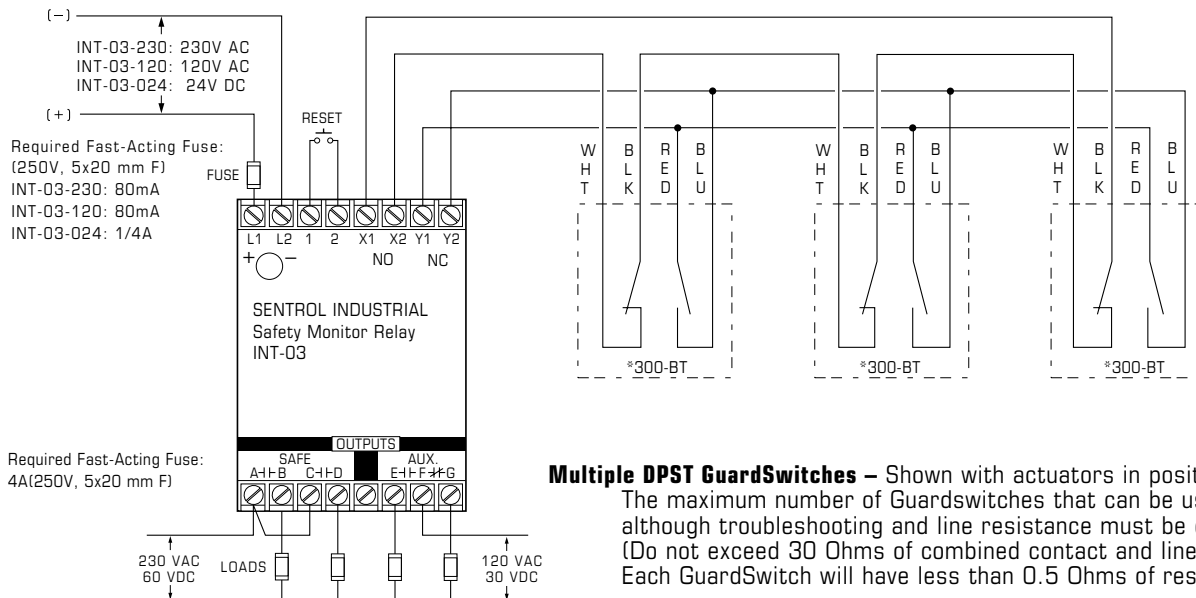

Multiple DPST GuardSwitches – Shown with actuators in position, all guards closed. The maximum number of Guardswitches that can be used is 50, although troubleshooting and line resistance must be considered. (Do not exceed 30 Ohms of combined contact and line resistance. Each GuardSwitch will have less than 0.5 Ohms of resistance.)

Wiring Diagram for Category 4

Inputs shown with safety gate/guard in closed position. Two Series 300-B GuardSwitches™ with one INT relay are required for each safety gate.

When first applying the INT Safety Monitor Relay, the inputs must be cycled to check for proper operation before the output contacts close. To cycle the inputs, the guard must be opened and then closed. This start-up test is sufficient; however, we recommend that the proper operation of the switches and relay be checked at least every 24 hours.

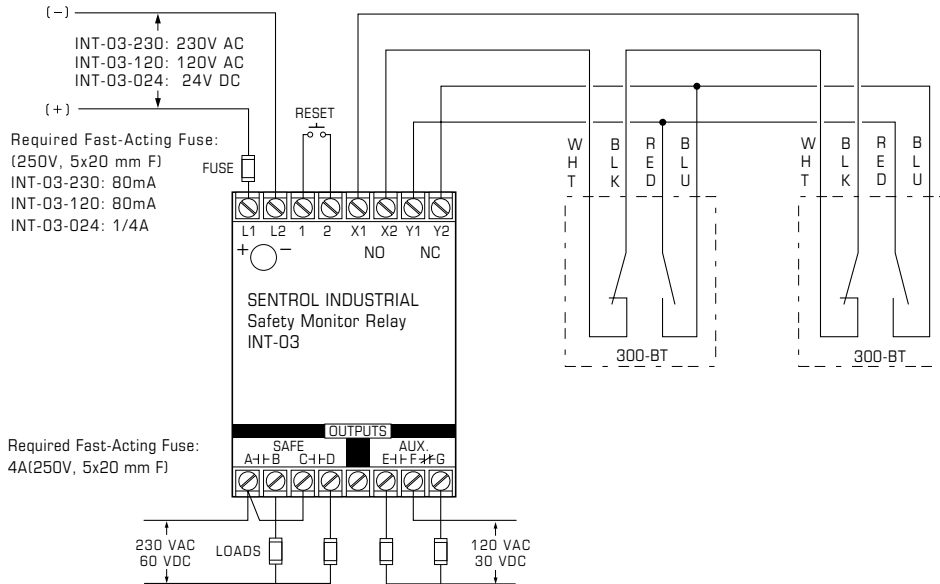

CE Compliance Information

These switches are TUV certified for CE applications only when used with the INT Safety Monitor Relays. See Risk Category 3 and Category 4 wiring diagrams above.

European Directives

Machinery Directive (89/392/EEC)

EMC Directive (89/336/EEC)

Low Voltage Directive (73/23/EEC)

Specific European Standards

EN60204-1 Safety of electrical equipment of industrial machines

EN292 Part 1, 2 Safety of Machinery, basic terminology, technical principles

EN954-1 Risk Assessment Category 3 or 4 depending on wiring method, see diagrams

EN55081-2 Electromagnetic Emissions

EN50082-2 Electromagnetic Immunity

EN1088 Interlocking Devices

EN947-5-3 Control Circuit Devices

EN50178 Safety of Electrical Equipment

IEC 664-1 Insulation requirements

IEC 68, part 2-1, 2-2, 2-3, 2-8, 2-14, 2-27, 2-30



Declaration of Conformity
available upon request.

General Specifications

Enclosure UL Explosion Proof, Die Cast Anodized Aluminum
 UL Enclosure Classified for Use in Hazardous Locations:
 Class I, Group B, C, D
 Class II, Group E, F, G
 Class III, Divisions 1 & 2

Temperature Range -40°F to 180°F (-40°C to 80°C)
 Environmental Hermetically Sealed Contact Switch Encapsulated in Polyurethane

NEMA Rating 1, 2, 5
 Protection Class IP 64
 Response Time 1 msec (individual circuits)

The two circuits do not switch simultaneously, and depend on the speed of the guard closure. Based on closure speed of 1' per second and a gap of 1/8", a delay less than 50 msec is typical.

Life Cycles 100,000 Under Full Load; Up to 200,000,000 Under Dry Circuit

Conduit Connection 1/2" Threaded NPT
 UL/CSA/TUV All Models

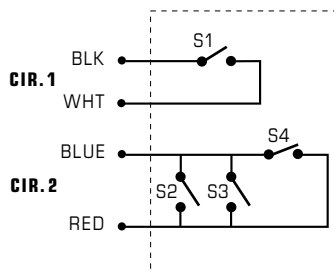

*Circuits shown with magnet actuator away from switch.

S1 Normally open reed switch, closed when actuator is within 0.6"
 S2, S3 Normally open reed switches, will close if misaligned or tampered with a standard magnet
 S4 Biased closed reed switch, open when actuator is between 0.3" and 0.6"

N.O. circuit: Black and white wires.
 N.C. biased tamper circuit: Red and blue wires.



FileE122942



LR8976

Electrical Specifications

Circuit No.	Circuit Type	Contact Configuration	Load Rating	Switching Voltage	Switching Current
1	Switch	N.O.	40W/VA	48VAC/VDC	1.0ADC, 0.7AAC
2	Tamper	N.C.	10W/VA	48VAC/VDC	0.3A

Ordering Information

Part Number	Contact ¹ Configuration	Sense Range ² Minimum	Sense Range ² Maximum	Break Range	Terminal Type
371-BT	DPST: 1 N.O., 1 N.C.	0.3"(0.8cm)	0.6"(1.5cm)	1.2"(3.0cm)	#6 screws

Accessories

Part Number	Tamper proof screws & screwdriver
1953	#6 x 3/4"L Tampruf Roundhead Screw
1954	#8 x 1-1/2"L Tampruf Roundhead Screw
1955	Tampruf® Screwdriver
1956	Tampruf® 1/4" Drive Bit for #6 and #8 Screws

Warning— Each electrical rating is an individual maximum and cannot be exceeded!

¹ Configuration with actuator away from the switch

² Proximity of ferrous materials usually reduces sense range — typically by 50%. The shape and type of material cause a wide diversity of effects. Testing is required to determine actual sense range for specific applications.

SENTROL INDUSTRIAL

12345 SW Leveton Dr., Tualatin, OR 97062
 Tel: **800-247-9447** Fax: **503-691-7563**
<http://www.sentrolindustrial.com>
 Technical Service: 800-648-7424
 FaxBack: 800-483-2495

Sentrol reserves the right to change specifications without notice.

©1999 Sentrol

SI-3706-0899
 1030523 Rev A

381 & 383-BT GuardSwitch

Safety Switch

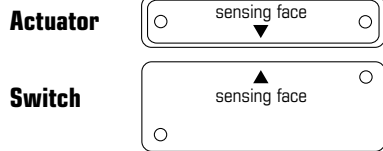
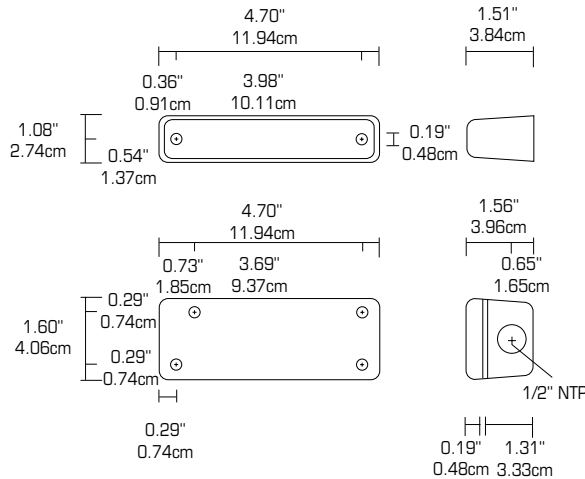

APPLICATIONS

- Packaging Machinery
- Machine Tool Machinery
- Presses
- Applications Requiring 1/2" Conduit Enclosures
- Meets European Safety Standard for the Highest Machine Risk Category when used with the INT Safety Relay

General Specifications

Enclosure	Coated Aluminum
Temperature Range	-40°F to 180°F (-40°C to 80°C)
Environmental	Hermetically Sealed Contact Switch Encapsulated in Polyurethane
NEMA Rating	1, 2, 5
Protection Class	IP 64
Response Time (individual circuits)	1 msec
Life Cycles	The two circuits do not switch simultaneously and depend on the speed of the guard closure. A delay less than 50 msec is typical. 100,000 Under Full Load; Up to 200,000,000 Under Dry Circuit
Conduit Connection	1/2" Threaded NPT
UL/CSA/TUV	All Models

ELECTRICAL SPECIFICATIONS

Circuit No.	Circuit Type	Contact Configuration	Load Rating	Switching Voltage	Switching Current
1	Switch	N.O.	40W/VA	48VAC/VDC	1.0ADC, 0.7AAC
2	Tamper	N.C.	10W/VA	48VAC/VDC	0.3A



File E 122942 LR89176



U9880128199005
When used with INT Safety Monitor Relay

ORDER INFORMATION					
Part Number ¹ 381 or 383	Contact ² Configuration	Sense Range ³ Minimum	Sense Range ³ Maximum	Break Range	Terminal Type
381-BT	DPST: 1 N.O., 1 N.C.	0.3"(0.8cm)	0.6"(1.5cm)	1.2"(3.0cm)	#6 screws

Warning— Each electrical rating is an individual maximum and cannot be exceeded!

¹ The part numbers 381 and 383 are the same in all respects except the conduit connection exits 381 left and 383 right.
² Configuration with actuator away from the switch
³ Proximity of ferrous materials usually reduces sense range — typically by 50%. The shape and type of material cause a wide diversity of effects. Testing is required to determine actual sense range for specific applications.

SENTROL INDUSTRIAL

12345 SW Leveton Drive, Tualatin, OR 97062

Tel: **800-247-9447** Fax: **503-691-7563**

http://www.sentrolindustrial.com

GuardSwitch™ Series 300 Safety Interlock Switch Installation Instructions



Description

The 381-BT Series DPST safety interlock switch is designed for use with safety monitored relays or monitored circuits. To achieve the optimum Series 300 defeat resistant feature of the 381-BT, both the switch circuit (Circuit 1) and the tamper circuit (Circuit 2) must be connected.

Notes:

1. Humidity Rating: 30 to 95%
2. Altitude Rating: Up to 1000m above sea level
3. Environmental: Pollution Degree II
4. Correct use of this control device is an essential part of proper machine cycle control.
5. Failure to follow ALL instructions could lead to serious bodily injury or death.
6. Maintenance to be done by qualified personnel only
7. The connecting cables between the INT devices and the switches must be located in an IP 23 type enclosure (minimum).
8. The mounting for the switch and the actuator magnet must be accomplished per this specification.
9. Non-removable hardware must be used for installation.
10. The housing of the 300-BT must be connected to the PE (Primary Earth) ground circuit via a lock washer on the mounting screw. The PE ground symbol must be placed adjacent to the screw.

Part Numbers

- 381-BT
- 381-B _____
- 383-BT
- 383-B _____

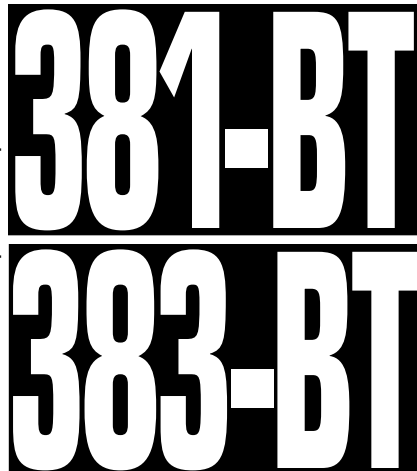

Installation

1. Position the switch and actuator so the labels are reading in the same direction (see Figure 1.)
2. Mount the switch on the stationary frame of the machine and mount the actuator on the moveable guard, door or gate. Keep the switch and actuator within the listed sense range. (See Ordering Information.)
See Figure 2 for recommended mounting configurations.
3. Mounting on a ferrous material will effect the sense range a minimum of 50%. However, a 1/4" non-ferrous spacer positioned under the actuator and/or switch should restore most of the lost sense range.
4. For best protection against operator defeat, mount with non-removable screws, bolts or nuts (see Accessories).
5. **CAUTION:** When not used with a Sentrol INT safety relay, particular care must be taken to determine the actual load of the switch circuit. High voltage transients from coils, motors, contactors, and solenoids must be considered. Transient protection, such as back-to-back zener diodes (TransZorb®) or an RC network, is recommended for such loads to ensure that maximum ratings of the switch are not exceeded. Not recommended to be used with tungsten filament loads because of high current inrush surges. Line capacitance and load capacitance must be considered. Excessive line capacitance can be caused by cable lengths over 50' when using a maximum 48 VAC. A resistor can be added in series to limit the inrush current (at least 48 Ohms for 24V applications). The resistor can be added in series just before the load. The voltage drop and the power rating of the resistor must be considered. Voltage drop = I•R; Watts = I²R (I = maximum continuous current of the load).

continued

Fax (503-691-7563) or mail to register your warranty

Warranty Registration

Sentrol Industrial warranties this device for 5 years from date of installation or purchase. To register this product for the warranty, fill out this form and fax or mail it to Sentrol Industrial at the address listed above. ALL INFORMATION IS REQUIRED.

Company name _____

Company purchased from _____

Street address _____

Date of purchase or installation _____

City, State, Zip _____

Quantity installed _____

Completed by (name, title) _____

Type of machine installed on _____

6. When mounting the switch on an ungrounded machine, ground the switch housing by connecting your ground lead to one of the switch mounting screws.

Dimensions

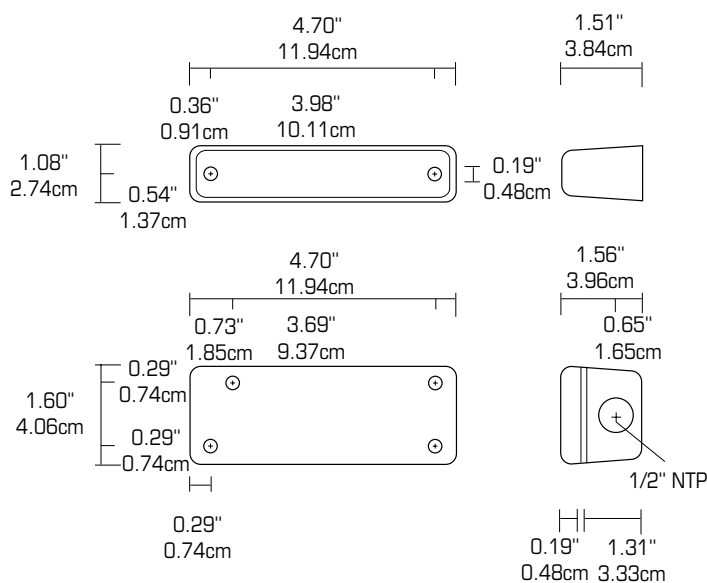
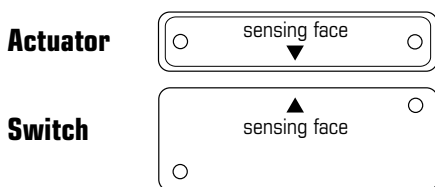
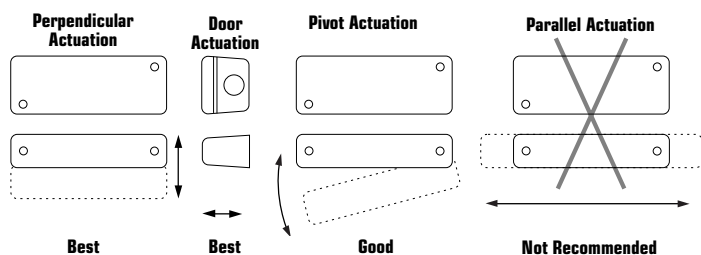

Figure 1



Mounting Configurations

Figure 2



The parallel actuation can result in on/off/on signal if the actuator passes by the switch rather than coming to rest in proximity to it. This is NOT a recommended configuration for safety interlock applications.

Wiring Diagram for Category 3

Inputs shown with safety gates/guards in closed position. One Series 300-BT GuardSwitch™ required for each safety gate.

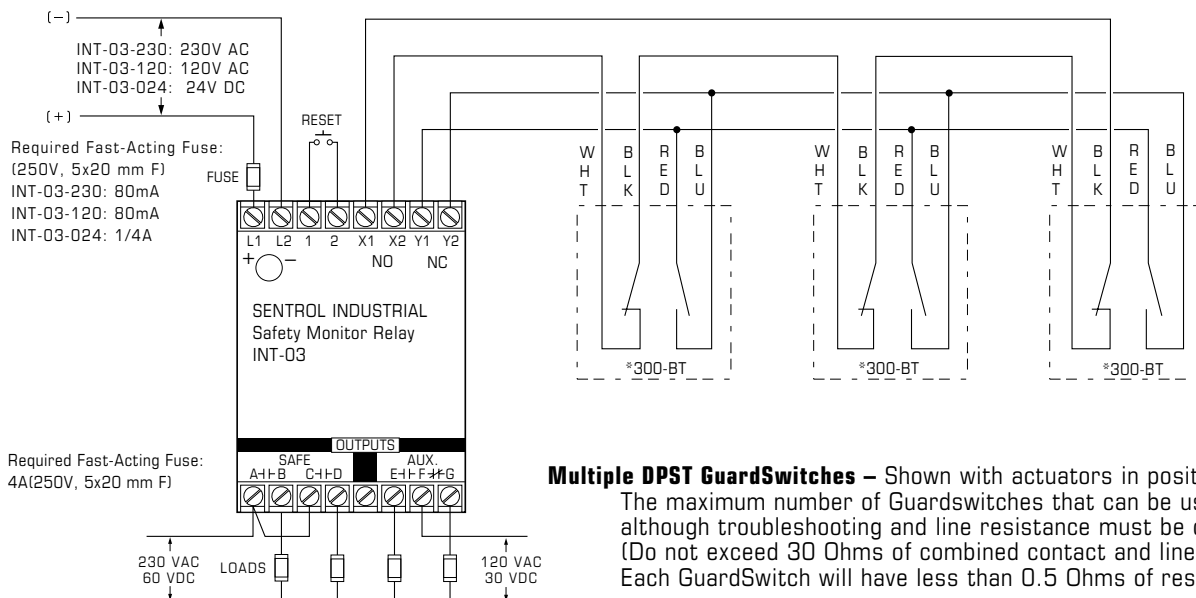

Multiple DPST GuardSwitches – Shown with actuators in position, all guards closed. The maximum number of Guardswitches that can be used is 50, although troubleshooting and line resistance must be considered. (Do not exceed 30 Ohms of combined contact and line resistance. Each GuardSwitch will have less than 0.5 Ohms of resistance.)

Wiring Diagram for Category 4

Inputs shown with safety gate/guard in closed position. Two Series 300-B GuardSwitches™ with one INT relay are required for each safety gate.

When first applying the INT Safety Monitor Relay, the inputs must be cycled to check for proper operation before the output contacts close. To cycle the inputs, the guard must be opened and then closed. This start-up test is sufficient; however, we recommend that the proper operation of the switches and relay be checked at least every 24 hours.

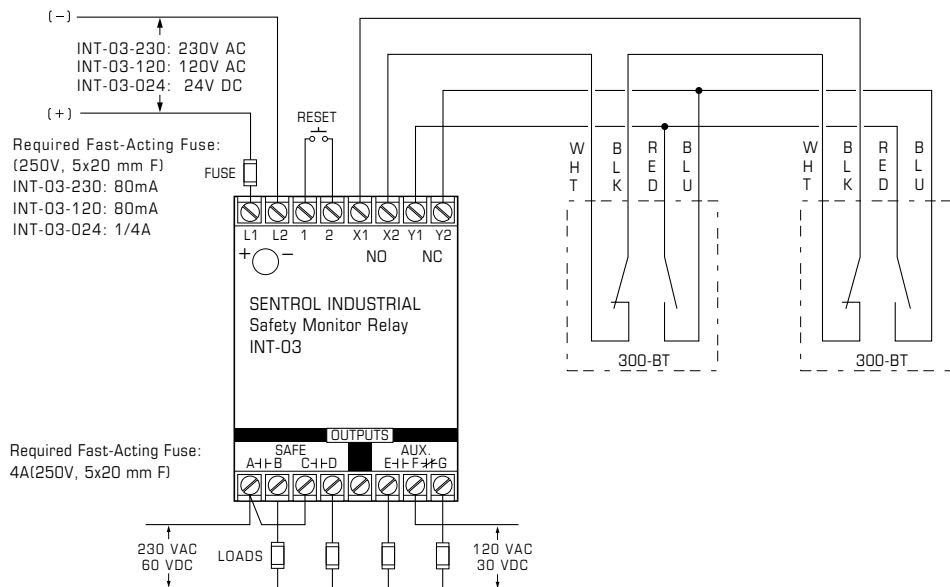

CE Compliance Information

These switches are TUV certified for CE applications only when used with the INT Safety Monitor Relays. See Risk Category 3 and Category 4 wiring diagrams above.

European Directives

Machinery Directive (89/392/EEC)

EMC Directive (89/336/EEC)

Low Voltage Directive (73/23/EEC)

Specific European Standards

EN60204-1 Safety of electrical equipment of industrial machines

EN292 Part 1, 2 Safety of Machinery, basic terminology, technical principles

EN954-1 Risk Assessment Category 3 or 4 depending on wiring method, see diagrams

EN55081-2 Electromagnetic Emissions

EN50082-2 Electromagnetic Immunity

EN1088 Interlocking Devices

EN947-5-3 Control Circuit Devices

EN50178 Safety of Electrical Equipment

IEC 664-1 Insulation requirements

IEC 68, part 2-1, 2-2, 2-3, 2-8, 2-14, 2-27, 2-30



General Specifications

Enclosure Coated Aluminum
 Temperature Range -40°F to 180°F (-40°C to 80°C)
 Environmental Hermetically Sealed Contact Switch
 Encapsulated in Polyurethane
 NEMA Rating 1, 2, 5
 Protection Class IP 64
 Response Time 1 msec
 (individual circuits) The two circuits do not switch simultaneously, and depend on the speed of the guard closure. Based on closure speed of 1' per second and a gap of 1/8", a delay less than 50 msec is typical.

Life Cycles 100,000 Under Full Load;
 Up to 200,000,000 Under Dry Circuit

Conduit Connection 1/2" Threaded NPT
 UL/CSA/TUV All Models

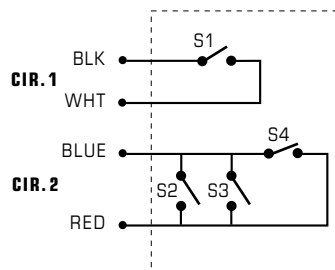

*Circuits shown with magnet actuator away from switch.

S1 Normally open reed switch, closed when actuator is within 0.6"
 S2, S3 Normally open reed switches, will close if misaligned or tampered with a standard magnet
 S4 Biased closed reed switch, open when actuator is between 0.3" and 0.6"

N.O. circuit: Black and white wires.
 N.C. biased tamper circuit: Red and blue wires.



File E122942



LR89176

Electrical Specifications

Circuit No.	Circuit Type	Contact Configuration	Load Rating	Switching Voltage	Switching Current
1	Switch	N.O.	40W/VA	48VAC/VDC	1.0ADC, 0.7AAC
2	Tamper	N.C.	10W/VA	48VAC/VDC	0.3A

Ordering Information

Part Number ¹	Contact ² Configuration	Sense Range ³ Minimum	Sense Range ³ Maximum	Break Range	Terminal Type
381-BT	DPST: 1 N.O., 1 N.C.	0.3"(0.8cm)	0.6"(1.5cm)	1.2"(3.0cm)	#6 screws
383-BT	DPST: 1 N.O., 1 N.C.	0.3"(0.8cm)	0.6"(1.5cm)	1.2"(3.0cm)	#6 screws

Accessories

Part Number	Tamper proof screws & screwdriver
1953	#6 x 3/4"L Tampruf Roundhead Screw
1954	#8 x 1-1/2"L Tampruf Roundhead Screw
1955	Tampruf® Screwdriver
1956	Tampruf® 1/4" Drive Bit for #6 and #8 Screws

Warning— Each electrical rating is an individual maximum and cannot be exceeded!

¹ The part numbers 381 and 383 are the same in all respects except the conduit connection exits 381 left and 383 right.

² Configuration with actuator away from the switch

³ Proximity of ferrous materials usually reduces sense range — typically by 50%. The shape and type of material cause a wide diversity of effects. Testing is required to determine actual sense range for specific applications.

SENTROL INDUSTRIAL

12345 SW Leveton Dr., Tualatin, OR 97062
 Tel: **800-247-9447** Fax: **503-691-7563**
<http://www.sentrolindustrial.com>
 Technical Service: 800-648-7424
 FaxBack: 800-483-2495

Sentrol reserves the right to change specifications without notice.

©1999 Sentrol

SI-3706-0899
 1030523 Rev A

391 & 393-BT GuardSwitch

Safety Switch

SAFETY
300-BT SERIES

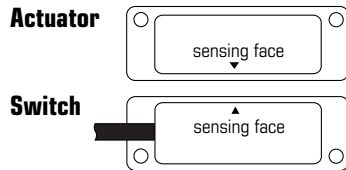
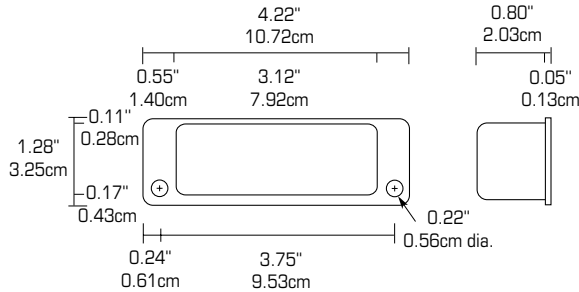

APPLICATIONS

- Machine Tool Machinery
- Withstands Corrosive and Extreme Washdown Environments
- Packaging Machinery
- Food Processing Machinery
- Presses
- Meets European Safety Standard for the Highest Machine Risk Category when used with the INT Safety Relay

General Specifications

Enclosure	Seamless 304 Stainless Steel
Temperature Range	-40°F to 180°F (-40°C to 80°C)
Environmental	Hermetically Sealed Contact Switch Encapsulated in Polyurethane
NEMA Rating	1, 2, 4, 4X, 5, 12, 12K
Protection Class	IP 67
Response Time (individual circuits)	1 msec The two circuits do not switch simultaneously and depend on the speed of the guard closure. A delay less than 50 msec is typical.
Life Cycles	100,000 Under Full Load; Up to 200,000,000 Under Dry Circuit
Lead Types/O.D.	18/4 SJTOW (K)/0.34" (0.86cm) 22/4 PVC Jacketed (J)/0.24" (0.62cm)
UL/CSA/TUV	All Models

ELECTRICAL SPECIFICATIONS

Circuit No.	Circuit Type	Contact Config.	Load Rating	Switching Voltage	Switching Current
1	Switch	N.O.	40W/VA	48VAC/VDC	1.0ADC, 0.7AAC
2	Tamper	N.C.	10W/VA	48VAC/VDC	0.3A
2	w/optional LED	N.C.	0.1-1.4W	48VDC(3V drop)	30mA



File E 115761 LR89176



U 9880128199005
When used with INT Safety Monitor Relay

ORDER INFORMATION

Part Number ¹ 391 or 393	Contact ² Configuration	Sense Range ³ Minimum	Sense Range ³ Maximum	Break Range	Lead Length
391-BT-06(J)(K)	DPST: 1 N.O., 1 N.C.	0.3"(0.8cm)	0.6"(1.5cm)	1.2"(3.0cm)	6' (1.8cm)
391-BT-12(J)(K)	DPST: 1 N.O., 1 N.C.	0.3"(0.8cm)	0.6"(1.5cm)	1.2"(3.0cm)	12' (3.6cm)
391-BLT-06(J)(K)	DPST: 1 N.O., 1 N.C. w/LED	0.3"(0.8cm)	0.6"(1.5cm)	1.2"(3.0cm)	6' (1.8cm)
391-BLT-12(J)(K)	DPST: 1 N.O., 1 N.C. w/LED	0.3"(0.8cm)	0.6"(1.5cm)	1.2"(3.0cm)	12' (3.6cm)

Warning— Each electrical rating is an individual maximum and cannot be exceeded!

¹ The part numbers 391 and 393 are the same in all respects except the cable exits 391 left and 393 right.

² Configuration with actuator away from the switch

³ Proximity of ferrous materials usually reduces sense range — typically by 50%. The shape and type of material cause a wide diversity of effects. Testing is required to determine actual sense range for specific applications.

SENTROL INDUSTRIAL

12345 SW Leveton Drive, Tualatin, OR 97062

Tel: **800-247-9447** Fax: **503-691-7563**

http://www.sentrolindustrial.com

GuardSwitch™ Series 300 Safety Interlock Switch Installation Instructions



Description

The 391-BT Series DPST safety interlock switch is designed for use with safety monitored relays or monitored circuits. To achieve the optimum Series 300 defeat resistance feature of the 391-BT, both the switch circuit (Circuit 1) and the tamper circuit (Circuit 2) must be connected. An optional third circuit can be provided to indicate at the panel which guard is open.

Notes:

1. Humidity Rating: 30 to 95%
2. Altitude Rating: Up to 1000m above sea level
3. Environmental: Pollution Degree II
4. Correct use of this control device is an essential part of proper machine cycle control.
5. Failure to follow ALL instructions could lead to serious bodily injury or death.
6. Maintenance to be done by qualified personnel only
7. The connecting cables between the INT devices and the switches must be located in an IP 23 type enclosure (minimum).
8. The mounting for the switch and the actuator magnet must be accomplished per this specification.
9. Non-removable hardware must be used for installation.
10. The housing of the 300-BT must be connected to the PE (Primary Earth) ground circuit via a lock washer on the mounting screw. The PE ground symbol must be placed adjacent to the screw.

Part Numbers

- 391-BT-06(J)(K)
- 391-BT-12(J)(K)
- 391-BLT-06(J)(K)
- 391-BLT-12(J)(K)
- 391-B3T-06J
- 391-B3T-12J
- 391-B3LT-06J
- 391-B3LT-12J
- 391-B_____
- 393-B_____



Installation

1. Position the switch and actuator so the labels are reading in the same direction (See Figure 1.)
2. Mount the switch on the stationary frame of the machine and mount the actuator on the moveable guard, door or gate. Keep the switch and actuator within listed sense range. (See Ordering Information.) See Figure 2 for recommended mounting configurations.
3. Mounting on a ferrous material will effect the sense range a minimum of 50%. However, a 1/4" non-ferrous spacer positioned under the magnet and/or switch should restore most of the lost sense range.
4. For best protection against operator defeat, mount with non-removable screws, bolts or nuts. See ordering information for details.
5. When not used with a Sentrol INT safety relay, particular care must be taken to determine the actual load of the switch circuit. High voltage transients from coils, motors, contactors and solenoids must be considered. Transient protection, such as back-to-back zener diodes (TransZorb®) or an RC network, is recommended for such loads to ensure that maximum ratings of the switch are not exceeded. Not recommended to be used with tungsten filament loads because of high current inrush surges. Line capacitance and load capacitance must be considered. Excessive line capacitance can be caused by cable lengths over 50' when using a maximum 48 VAC. A resistor can be added in series to limit the inrush current (at least 48 ohms for 24 Volt applications). The resistor can be added in series just before the load. The voltage drop and the power rating of the resistor must

continued

Fax (503-691-7563) or mail to register your warranty

Warranty Registration

Sentrol Industrial warranties this device for 5 years from date of installation or purchase. To register this product for the warranty, fill out this form and fax or mail it to Sentrol Industrial at the address listed above. ALL INFORMATION IS REQUIRED.

Company name _____

Company purchased from _____

Street address _____

Date of purchase or installation _____

City, State, Zip _____

Quantity installed _____

Completed by (name, title) _____

Type of machine installed on _____

Wiring Diagram for Category 4

Inputs shown with safety gate/guard in closed position. Two Series 300-BT GuardSwitches™ with one INT relay are required for each safety gate.

When first applying the INT Safety Monitor Relay, the inputs must be cycled to check for proper operation before the output contacts close. To cycle the inputs, the guard must be opened and then closed. This start-up test is sufficient; however, we recommend that the proper operation of the switches and relay be checked at least every 24 hours.

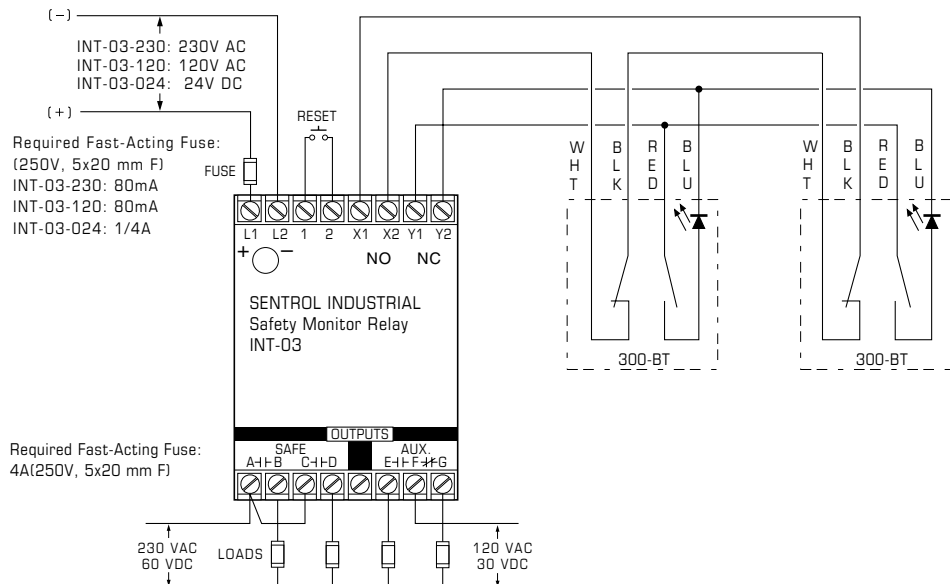

CE Compliance Information

These switches are TUV certified for CE applications only when used with the INT Safety Monitor Relays. See Risk Category 3 and Category 4 wiring diagrams above.

European Directives

Machinery Directive (89/392/EEC)

EMC Directive (89/336/EEC)

Low Voltage Directive (73/23/EEC)

Specific European Standards

EN60204-1 Safety of electrical equipment of industrial machines

EN292 Part 1, 2 Safety of Machinery, basic terminology, technical principles

EN954-1 Risk Assessment Category 3 or 4 depending on wiring method, see diagrams

EN55081-2 Electromagnetic Emissions

EN50082-2 Electromagnetic Immunity

EN1088 Interlocking Devices

EN947-5-3 Control Circuit Devices

EN50178 Safety of Electrical Equipment

IEC 664-1 Insulation requirements

IEC 68, part 2-1, 2-2, 2-3, 2-8, 2-14, 2-27, 2-30



General Specifications

Enclosure Seamless 304 Stainless Steel
 Temperature Range -40°F to 180°F (-40°C to 80°C)
 Environmental Hermetically Sealed Contact Switch
 Encapsulated in Polyurethane
 NEMA Rating 1, 2, 4, 4X, 5, 12, 12K
 Protection Class IP 67
 Response Time 1 msec
 (individual circuits)

The two circuits do not switch simultaneously, and depend on the speed of the guard closure. Based on closure speed of 1' per second and a gap of 1/8", a delay less than 50 msec is typical.

Life Cycles 100,000 Under Full Load;
 Up to 200,000,000 Under Dry Circuit
 Lead Type 18/4 SJTOW(K)/0.34" (0.86cm)
 22/4 PVC Jacketed (J)/0.19" (0.48cm)
 22/6 PVC Jacketed (J)/0.21" (0.53cm)
 UL/CSA/TUV All Models

For additional options and alternate specifications, consult factory.

Electrical Specifications

Circuit No.	Circuit Type	Contact Config.	Load Rating	Switching Voltage	Switching Current
1	Switch	N.O.	40W/VA	48VAC/VDC	1.0ADC, 0.7AAC
2	Tamper	N.C.	10W/VA	48VAC/VDC	0.3A
2	w/optional LED	N.C.	0.1–1.4W	48VDC(3V drop)	30mA
3	Monitor	N.O.	10W/VA	48VAC/VDC	0.3ADC, 0.3AAC

Ordering Information

Part Number ¹ 391 or 393	Contact ² Configuration	Sense Range ³ Minimum	Sense Range ³ Maximum	Break Range	Lead Length
391-BT-06(J)(K)	DPST: 1 N.O., 1 N.C.	0.3"(0.8cm)	0.6"(1.5cm)	1.2"(3.0cm)	6' (1.8cm)
391-BT-12(J)(K)	DPST: 1 N.O., 1 N.C.	0.3"(0.8cm)	0.6"(1.5cm)	1.2"(3.0cm)	12' (3.6cm)
391-BLT-06(J)(K)	DPST: 1 N.O., 1 N.C. w/LED	0.3"(0.8cm)	0.6"(1.5cm)	1.2"(3.0cm)	6' (1.8cm)
391-BLT-12(J)(K)	DPST: 1 N.O., 1 N.C. w/ LED	0.3"(0.8cm)	0.6"(1.5cm)	1.2"(3.0cm)	12' (3.6cm)
391-B3T-06(J)	TPST: 2 N.O., 1 N.C.	0.3"(0.8cm)	0.6"(1.5cm)	1.2"(3.0cm)	6' (1.8cm)
391-B3T-12(J)	TPST: 2 N.O., 1 N.C.	0.3"(0.8cm)	0.6"(1.5cm)	1.2"(3.0cm)	12' (3.6cm)
391-B3LT-06(J)	TPST: 2 N.O., 1 N.C. w/LED	0.3"(0.8cm)	0.6"(1.5cm)	1.2"(3.0cm)	6' (1.8cm)
391-B3LT-12(J)	TPST: 2 N.O., 1 N.C. w/LED	0.3"(0.8cm)	0.6"(1.5cm)	1.2"(3.0cm)	12' (3.6cm)

Accessories

Part Number	Tamper proof screws & screwdriver
1953	#6 x 3/4"L Tampruf Roundhead Screw
1954	#8 x 1-1/2"L Tampruf Roundhead Screw
1955	Tampruf® Screwdriver
1956	Tampruf® 1/4" Drive Bit for #6 and #8 screws

Warning— Each electrical rating is an individual maximum and cannot be exceeded!

¹ The part numbers 391 and 393 are the same in all respects except the cable exits 391 left and 393 right.

² Configuration with actuator away from the switch

³ Proximity of ferrous materials usually reduces sense range — typically by 50%. The shape and type of material cause a wide diversity of effects. Testing is required to determine actual sense range for specific applications.

SENTROL INDUSTRIAL

12345 SW Leveton Dr., Tualatin, OR 97062
 Tel: **800-247-9447** Fax: **503-691-7563**
<http://www.sentrolindustrial.com>
 Technical Service: 800-648-7424
 FaxBack: 800-483-2495

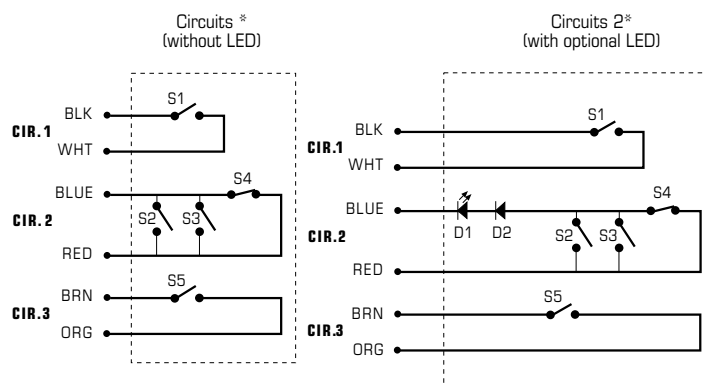

*Circuits shown with actuator away from switch.

S1, S5 Normally open reed switch¹, closed when actuator is within 0.6"
 S2, S3 Normally open reed switches, will close if misaligned or tampered with a standard magnet
 S4 Biased closed reed switch¹, open when actuator is between 0.3" and 0.6"

N.O. circuit: Black and white wires.
 N.C. biased tamper circuit: Red and blue wires.
 N.O. monitor circuit: Orange and brown wires.



FileE122942



LR89176

Sentrol reserves the right to change specifications without notice.

©1999 Sentrol

SI-3706-0899
 1030523 Rev A

Installation Instructions

Series 300-BT Safety Switches

Mounting Configurations

The interlock switch and actuator should be mounted in only three configurations for actuation:

Figure 1

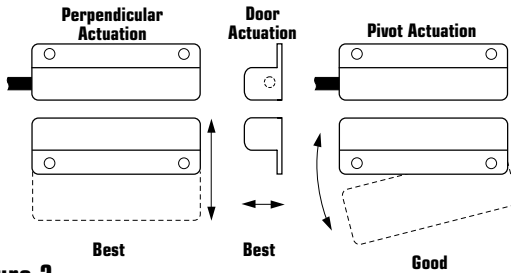
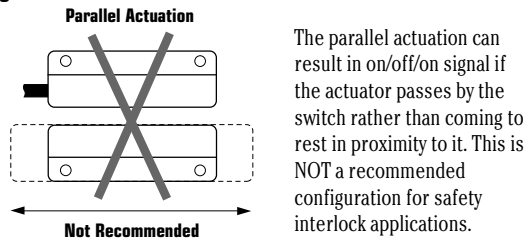
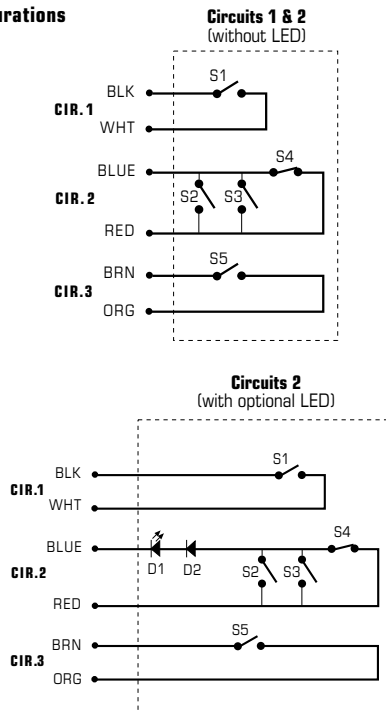

Figure 2



Circuit Configurations



*Circuits shown with magnet actuator away from switch.

- S1 Normally open reed switch, closed when actuator is within 0.4"
- S2, S3 Normally open reed switches, will close if misaligned or tampered with a standard magnet
- S4 Biased closed reed switch, open when actuator is between 0.15" and 0.4"
- S5 Normally open reed switch, closed when actuator is within 0.4"

INSTALLATION

1. Position the switch and actuator so the labels are reading in the same direction.
2. Mount the switch on the stationary frame of the machine and mount the actuator on the moveable guard, door or gate. Keep the switch and actuator within the listed sense range.

See diagram shown for recommended mounting configurations.

3. Mounting on a ferrous material will effect the sense range a minimum of 50%. However, a 1/4" non-ferrous spacer positioned under the actuator and/or switch should restore most of the lost sense range.
4. For best protection against operator defeat, mount with non-removable screws, bolts or nuts (see Accessories).

5. **CAUTION:** When not used with the INT safety relays particular care must be taken to determine the actual load of the switch circuit. High voltage transients from coils, motors, contactors, and solenoids must be considered. Transient protection, such as back-to-back zener diodes (TransZorb®) or an RC network, is recommended for such loads to ensure that maximum ratings of the switch are not exceeded. Not recommended to be used with tungsten filament loads because of high current inrush surges. Line capacitance and load capacitance must be considered. Excessive line capacitance can be caused by cable lengths over 50' when using a maximum 48 VAC. A resistor can be added in series to limit the inrush current (at least 48 Ohms for 24V applications). The resistor can be added in series just before the load. The voltage drop and the power rating of the resistor must be considered. $Voltage\ drop = I \cdot R$; $Watts = I^2 R$ (I = maximum continuous current of the load).

6. When mounting the switch on an ungrounded machine, ground the switch housing by connecting your ground lead to one of the switch mounting screws.

- N.O. circuit: Black and white wires.
- N.C. biased tamper circuit: Red and blue wires.
- N.O. monitor circuit: Orange and brown wires.

Installation Instructions

Series 300-BT Safety Switches

SAFETY
300-BT SERIES

Wiring Diagram For Category 3

Inputs shown with safety gates/guards in closed position.
One 300-BT Series GuardSwitch required for each safety gate.

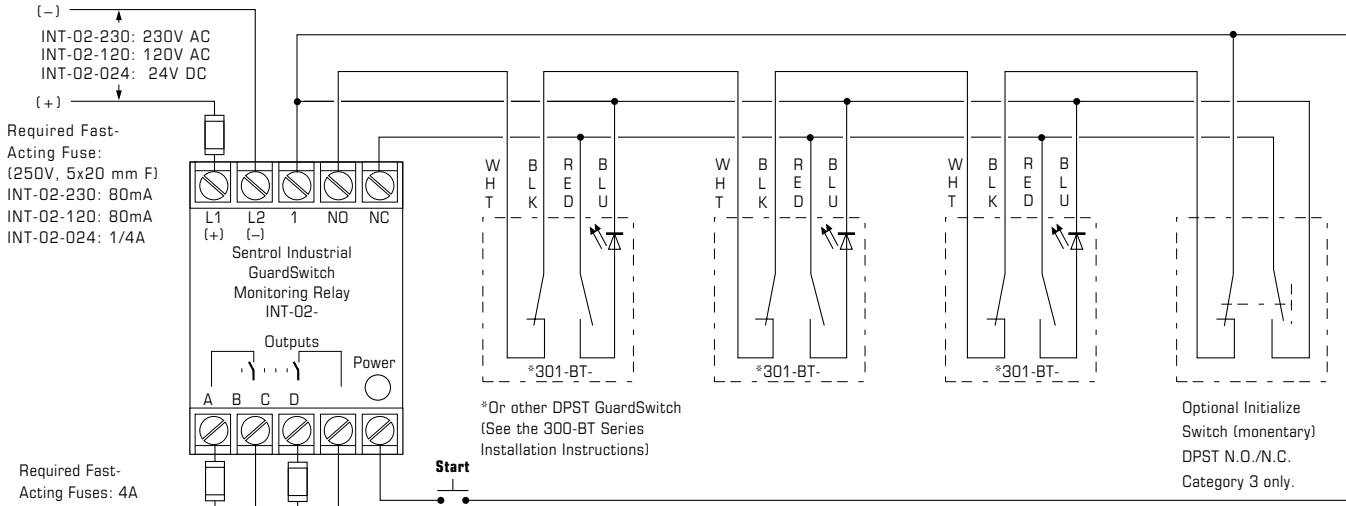

Multiple DPST GuardSwitches - Shown with actuators in position, all guards closed. The L.E.D. of the Series 300-BT model will be on when the guard is open. If multiple guards are open, the L.E.D. will be dimmer. The maximum number of GuardSwitches that can be used is 50, although troubleshooting and the resistance must be considered. (Do not exceed 30 ohms of combined contact and line resistance. Each GuardSwitch will have less than 0.5 ohms of resistance.)

Wiring Diagram For Category 4

Inputs shown with safety gates/guards in closed position.
Two 300-BT Series GuardSwitches with one INT relay are required for each safety gate.

When first applying the GuardSwitch Monitor Relay, the inputs must be cycled to check for proper operation before the output contact close. To cycle the inputs, the guard must be opened and then closed. This start-up test is sufficient; however, we recommend that the proper operation of the switches and relay be checked at least every 24 hours.

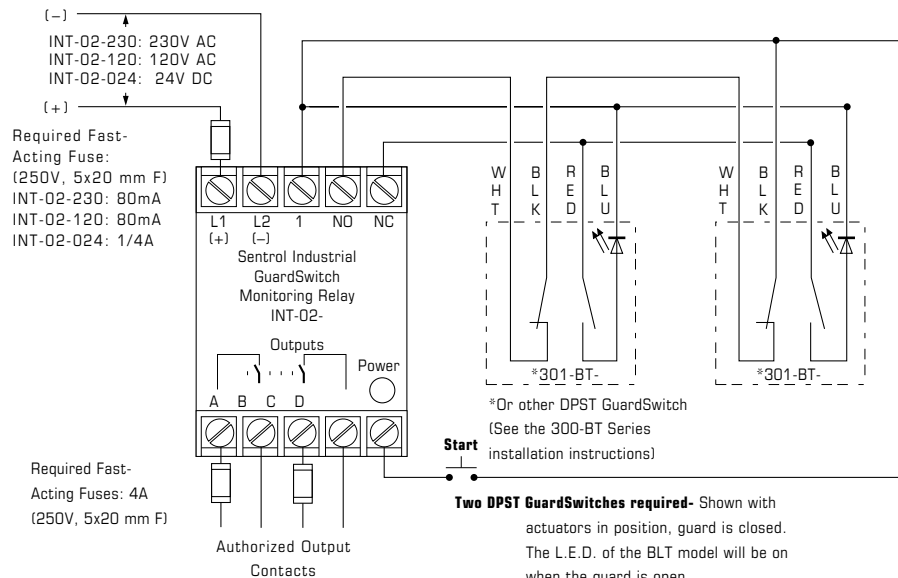

Installation Instructions

Series 300-BT Safety Switches



Declaration of Conformity available upon request.

CE COMPLIANCE INFORMATION

These switches are TÜV certified for CE applications only when used with the INT Series GuardSwitch Monitor Relays. See Risk Category 3 and Category 4 wiring diagrams.

European Directives

- Machinery Directive (89/392/EEC)
- EMC Directive (89/336/EEC)
- Low Voltage Directive (73/23/EEC)

Specific European Standards

- | | |
|---|---|
| <ul style="list-style-type: none"> EN60204-1 EN292 Part 1, 2 prEN954-1 EN55081-2 EN550082-2 EN1088 prEN 947-5-3 prEN 50178 IEC 664-1 IEC 68 | <ul style="list-style-type: none"> Safety of electrical equipment of industrial machines. Safety of Machinery, basic terminology, technical principles. Risk Assessment Category 3 or 4 depending on wiring method, see diagrams. Electromagnetic Emissions. Electromagnetic Immunity. Interlocking Devices. Control Circuit Devices. Safety of Electrical Equipment. Insulation requirements. part 2-1, 2-2, 2-3, 2-8, 2-14, 2-27, 2-30. |
|---|---|

Notes

1. Humidity Rating: 30 to 95%
2. Altitude Rating: Up to 1000m above sea level.
3. Environment: Pollution Degree II.
4. Correct use of this control devise is an essential part of proper machine cycle control.
5. Failure to follow ALL instructions could lead to serious bodily injury or death.
6. Maintenance to be done by qualified personnel only.
7. The connecting cables between the INT devices and the switches must be located in an IP 23 type enclosure (minimum).
8. The mounting for the switch and the acuator must be accomplished per this specification.
9. Non-removable hardware must be used for installation.
10. The housing of the 300-BT Series GuardSwitches must be connected to the PE (Primary Earth) ground circuit via a lock washer on the mounting screw. The PE ground symbol must be placed adjacent to the screw.

ACCESSORIES

Part Number	Tamper proof screws & screwdriver
1953	#6 x 3/4"L Tampruf Roundhead Screw
1954	#8 x 1-1/2"L Tampruf Roundhead Screw
1955	Tampruf® Screwdriver
1956	Tampruf® 1/4" Drive Bit for #6 and #8 Screws